



**Power  
Transmission**



# **Quick, easy and precise**

**Hydraulic hub-shaft connections**



# ETP-EXPRESS®

**For fast mounting and compact design**

ETP-EXPRESS is a hydraulic connection which has only one screw for pressurising. It is especially suitable for repositioning of the hub fast and accurately. The screw is tightened in the radial direction, this means no space is used along the shaft for mounting tools. Other components can be mounted on the shaft all the way up to the flange. ETP-EXPRESS has extremely small built-in dimensions which makes a compact design possible.



5727





**For fast  
mounting**



ETP-EXPRESS is available as standard for shafts 15-100 mm, also imperial. Runout  $\leq 0,02$  mm. Number of mountings 500 - 2 000 (size dependent). The extremely thin built-in dimensions allows for a compact design with low weight and inertia.

#### Construction

ETP-EXPRESS is a hydraulic connection which consists of a double-walled hardened steel sleeve filled with a pressure medium and a flange. The flange part contains screw and piston with seals to maintain pressure.

#### Operation

When the pressure screw is tightened, the double-walled sleeve expands uniformly against shaft and hub and creates a rigid joint. Dismantling is done by loosening the screw. ETP-EXPRESS returns to its original dimensions and can easily be dismantled.

*When the pressure screw is tightened to the recommended tightening torque, the piston has reached the bottom of the bore. ETP-EXPRESS has created a uniform surface pressure against the shaft and hub.*

#### Benefits and features

- Extremely fast mounting/dismantling with only ONE screw.
- Extremely small built-in dimensions.
- Radial tightening of the screw saves space along the shaft.
- Accurate positioning, no axial movement when mounting.
- Good concentricity, also after several mountings.

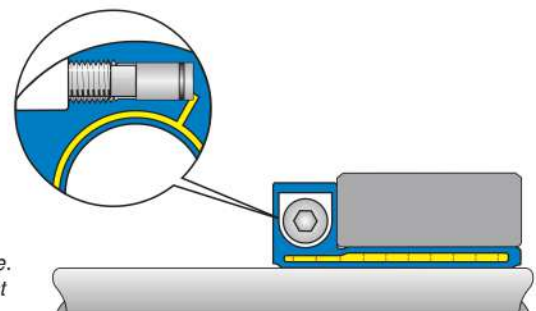

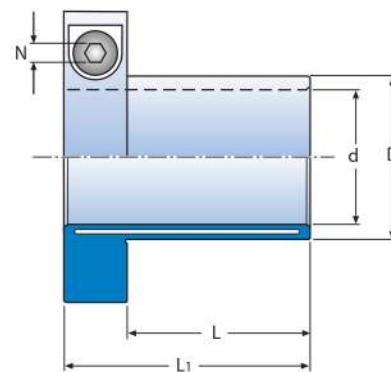
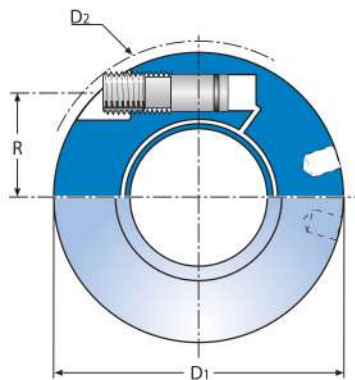

Notation: ETP-EXPRESS XXX

### Technical specification ETP-EXPRESS®

ETP-EXPRESS®	Dimensions						Transmittable			Screws DIN 915, 12.9				Polar moment of inertia J kgm <sup>2</sup> · 10 <sup>-3</sup>	Weight kg
	d mm	D mm	D <sub>1</sub> mm	D <sub>2</sub> * mm	L mm	L <sub>1</sub> mm	torque T Nm	axial force F <sub>A</sub> kN	radial force F <sub>R</sub> kN	Dim.	R mm	N mm	Tt Nm		
15	15	18	46	48,9	25	39	46	5,1	0,5	M10	15,1	5	5	0,04	0,16
5/8"	15,875	19	47	49,8	26	40	53	5,5	0,5	M10	15,6	5	5	0,05	0,17
19	19	23	50,5	53,0	28	42	85	7,3	1	M10	17,4	5	5	0,06	0,20
3/4"	19,05	23	50,5	53,0	28	42	85	7,3	1	M10	17,4	5	5	0,06	0,20
20	20	24	51,5	54,1	30	44	110	9,1	1	M10	18	5	5	0,07	0,21
22	22	27	55,5	60,5	32	46	130	9,6	1,2	M10	19,3	5	5	0,10	0,25
7/8"	22,225	27	55,5	60,5	32	46	130	9,6	1,2	M10	19,3	5	5	0,10	0,25
24	24	29	57,5	62,3	33	47	190	13	1,4	M10	20,3	5	5	0,11	0,27
25	25	30	58	62,9	35	49	230	15	1,5	M10	20,8	5	5	0,12	0,27
1"	25,4	31	59	63,8	35	49	190	12	1,5	M10	21,2	5	5	0,13	0,29
28	28	34	63	69,6	38	52	280	16	1,8	M10	22,6	5	5	0,17	0,34
1 1/8"	28,575	35	63,5	70,1	39	53	290	16	1,8	M10	23	5	5	0,18	0,35
30	30	36	64,5	71,0	40	54	380	21	2	M10	23,6	5	5	0,19	0,35
1 1/4"	31,75	39	68,5	77,7	42	56	430	22	2,2	M10	24,8	5	5	0,25	0,42
32	32	39	68,5	77,7	42	56	440	22	2,2	M10	24,8	5	5	0,25	0,42
1 3/8"	34,925	42	73	85,1	45	59	640	30	2,5	M10	26,4	5	5	0,32	0,48
35	35	42	73	85,1	45	59	640	30	2,5	M10	26,4	5	5	0,32	0,48
1 7/16"	36,5125	44	74,5	86,6	48	62	740	33	2,6	M10	27,3	5	5	0,36	0,52
38	38	46	84,5	89,5	52	72	890	38	2,8	M16	31	8	21	0,76	0,84
1 1/2"	38,1	46	84,5	89,5	52	72	890	38	2,8	M16	31	8	21	0,76	0,84
40	40	48	86,5	91,2	55	75	1100	45	3	M16	32	8	21	0,84	0,88
42	42	51	89	93,5	56	76	1100	43	3,2	M16	33,2	8	21	0,97	0,96
1 3/4"	44,45	54	93	100,3	58	78	1400	51	3,5	M16	34,8	8	21	1,20	1,10
45	45	54	93	100,3	58	78	1400	51	3,5	M16	34,8	8	21	1,17	1,05
48	48	59	97	103,8	59	79	1700	57	4	M16	36,8	8	21	1,46	1,21
1 15/16"	49,2125	60	98,5	105,1	60	80	1900	63	4,3	M16	37,5	8	21	1,57	1,27
50	50	60	98,5	105,1	60	80	1900	63	4,5	M16	37,5	8	21	1,52	1,20
2"	50,8	61	101,5	111,8	60	80	1900	62	4,5	M16	38	8	21	1,72	1,28
55	55	67	106	115,9	65	85	2400	71	5	M16	40,5	8	21	2,18	1,50
60	60	73	115,5	132,7	70	90	3300	90	5,3	M16	43,3	8	21	3,17	1,85
65	65	79	120,5	137	75	95	4400	112	5,6	M16	46,1	8	21	4,1	2,13
2 1/2"	63,5	77	119	134,6	73	93	4000	105	5,4	M16	45,1	8	21	3,74	2,04
70	70	85	135,5	153,9	85	109	5600	130	6,4	M20	50,8	10	39	7,12	3,04
3"	76,2	92	141,5	157,8	91	115	7500	160	7	M20	54,1	10	39	9,01	3,48
80	80	97	145,5	162,6	95	119	8700	180	7,5	M20	56,3	10	39	10,35	3,75
90	90	109	155,5	171,7	105	129	12000	220	8,6	2 x M20**	61,8	10	39	15,20	4,80
100	100	121	166	181,0	115	139	17000	280	9,7	2 x M20**	67,3	10	39	21,90	5,90

T= Transmittable torque when axial force is 0. } When the screw/screws is tightened to Tt  
 F<sub>A</sub>=Transmittable axial force when torque is 0.  
 F<sub>R</sub>=Max transmittable radial force at continuous operation.  
 Max allowed bending torque: 5% of transmittable torque T.

Tt= Recommended tightening torque for the screw/screws.  
 Further tightening does not increase the pressure.  
 \*) D2 is valid before mounting.  
 \*\*) Pressure screws positioned in the same direction.  
 Dimensions subject to alterations without notice.

#### TOLERANCES

Shaft h7 for d =15 mm.

Shaft k6-h7 for d = 19, 22, 24, 28, 32, 38, 42, 48, 55 mm.

Shaft h8 for all other dimensions d.

Hub H7.

For further information see section Technical information/Design tips, page 52-55.

#### Type of torque

Transmittable torque, T, is for static load.

If the load is alternating or pulsating torque, reduce the transmittable torque, T, with the following factors: (factor x T).

**Alternating: 0,5 x T.**

**Pulsating: 0,6 x T.**



# ETP-EXPRESS® R

**Corrosion resistant  
and easy to clean**



The demand from the food and process industries is increasing for stainless steel hub-shaft connections. The most common sizes of the hydraulic connection ETP-EXPRESS are available in stainless steel. The flat flange design allows for easy cleaning, essential within food processing.

Also the pressure medium and screw lubricant are approved for use in the food industry.





ETP-EXPRESS R is available as standard for shafts 15-80 mm, also imperial. Runout  $\leq 0,02$  mm. Number of mountings 200 – 800 (size dependent). The extremely thin built-in dimensions allows for a compact design with low weight and inertia.

#### Construction

ETP-EXPRESS R is a hydraulic connection which consists of a double-walled hardened stainless steel sleeve filled with a pressure medium, and a flange. The flange part contains a stainless screw and piston with seals to maintain pressure.

#### Operation

When the pressure screw is tightened the double-walled sleeve expands uniformly against shaft and hub and creates a rigid joint. Dismantling is done by loosening the screw. ETP-EXPRESS R returns to its original dimensions and can easily be dismantled.

#### Benefits and features

- ETP-EXPRESS R have the same benefits and features as ETP-EXPRESS.
- All parts exposed to the environment are made of stainless steel.
- Flat flange design allows for easy cleaning.
- Pressure medium and screw lubricant are food approved.

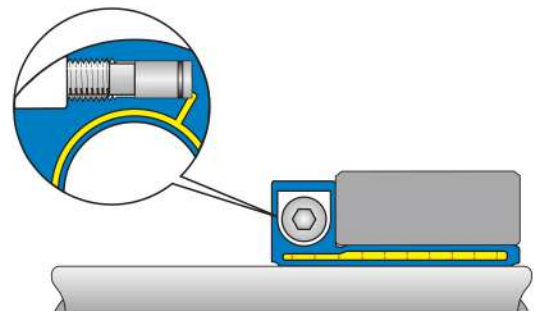

*When the pressure screw is tightened to the recommended tightening torque, the piston has reached the bottom of the bore. ETP-EXPRESS R has created a uniform surface pressure against the shaft and hub.*

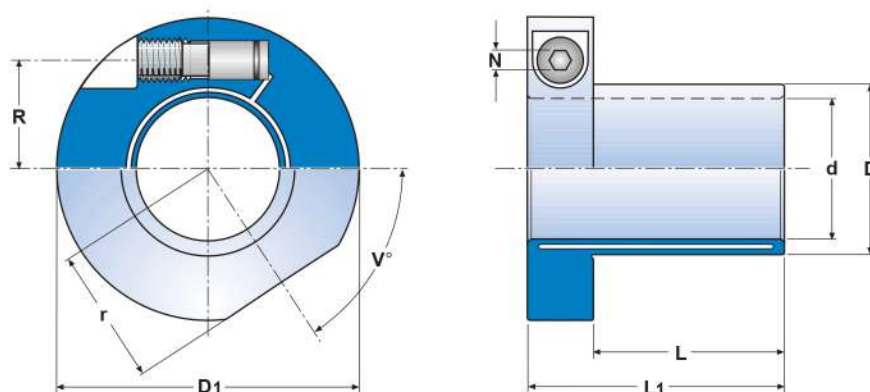

Notation ETP-EXPRESS R-XX

### Technical specification ETP-EXPRESS® R

ETP-EXPRESS®	Dimensions								Transmittable			Screw**) DIN 915, A4				Polar moment of inertia $J$ $\text{kgm}^2 \cdot 10^{-3}$	Weight kg
	d mm	D mm	D <sub>1</sub> mm	D <sub>2</sub> * mm	L mm	L <sub>i</sub> mm	r mm	V°	torque T Nm	axial force F <sub>A</sub> kN	radial force F <sub>R</sub> kN	Dim.	R mm	N mm	T <sub>t</sub> Nm		
<b>STAINLESS</b>																	
R-15	15	18	46	48,9	25	39	19,9	53	46	5,1	0,5	M10	15,1	5	5	0,04	0,16
R-5/8"	15,875	19	47	49,8	26	40	20,3	54	53	5,5	0,5	M10	15,6	5	5	0,05	0,17
R-3/4"	19,05	23	50,5	53,0	28	42	21,9	55	85	7,3	1	M10	17,4	5	5	0,06	0,20
R-20	20	24	51,5	54,1	30	44	22,6	56	110	9,1	1	M10	18	5	5	0,07	0,21
R-7/8"	22,225	27	55,5	60,5	32	46	24,4	57	130	9,6	1	M10	19,3	5	5	0,10	0,25
R-25	25	30	58	62,9	35	49	25,8	58	230	15	1,5	M10	20,8	5	5	0,12	0,27
R-1"	25,4	31	59	63,8	35	49	26,1	58	190	12	1,5	M10	21,2	5	5	0,13	0,29
R-1 1/8"	28,575	35	63,5	70,1	39	53	28,5	59	290	16	1,8	M10	23	5	5	0,18	0,35
R-30	30	36	64,5	71,0	40	54	29,1	59	380	21	2	M10	23,6	5	5	0,19	0,35
R-1 1/4"	31,75	39	68,5	77,7	42	56	31,1	58	430	22	2,2	M10	24,8	5	5	0,25	0,42
R-1 3/8"	34,925	42	73	85,1	45	59	31,9	60,5	640	30	2,5	M10	26,4	5	5	0,31	0,47
R-35	35	42	73	85,1	45	59	33,7	58	640	30	2,5	M10	26,4	5	5	0,32	0,48
R-1 1/2"	38,1	46	84,5	89,5	52	72	36,6	58	890	38	2,8	M16	31	8	21	0,76	0,84
R-40	40	48	86,5	91,2	55	75	37,7	59	1100	45	3	M16	32	8	21	0,84	0,88
R-1 3/4"	44,45	54	93	100,3	58	78	41,1	61	1400	51	3,5	M16	34,8	8	21	1,19	1,08
R-45	45	54	93	100,3	58	78	41,1	59	1400	51	3,5	M16	34,8	8	21	1,17	1,05
R-1 15/16"	49,2125	60	98,5	105,1	60	80	43,7	62	1900	63	4,5	M16	37,5	8	21	1,55	1,25
R-50	50	60	98,5	105,1	60	80	43,7	60	1900	63	4,5	M16	37,5	8	21	1,52	1,20
R-2"	50,8	61	101,5	111,8	60	80	45,2	60	1900	62	4,5	M16	38	8	21	1,72	1,28
R-60	60	73	115,5	132,7	70	90	53,3	59	3300	90	5,3	M16	43,3	8	21	3,17	1,85
R-70	70	85	135,5	153,9	85	109	62	59	5600	130	6,4	M20	50,8	10	39	7,12	3,04
R-80	80	97	145,5	162,6	95	119	65,9	61	8700	180	7,5	M20	56,3	10	39	10,35	3,75

T= Transmittable torque when axial force is 0.  
 F<sub>A</sub>=Transmittable axial force when torque is 0.  
 F<sub>R</sub>=Max transmittable radial force at continuous operation.  
 Max allowed bending torque: 5% of transmittable torque T.

T<sub>t</sub>= Recommended tightening torque for the screw.  
 Further tightening does not increase the pressure.  
 \*) D2 is valid before mounting.  
 Dimensions subject to alterations without notice.

#### Tolerances

Shaft h8 ( R-15 only h7).  
 Hub H7.

#### Type of torque

Transmittable torque, T, is for static load. If the load is alternating or pulsating torque, reduce the transmittable torque, T, with the following factors: (factor x T).

Alternating: 0,5 x T.  
 Pulsating: 0,6 x T.

#### Material

Type R: Euronorm 1.4057, stainless steel, X19CrNi17-2.

\*\*)Screw: coated for a low and even friction in the threads.

#### Mounting advice

Make sure the screw thread is well lubricated before each mounting. We recommend the use of Omega 58.

#### Special versions on request

ETP-EXPRESS R can be delivered in more corrosion resistant stainless steel and plated with Nickel.

For further information see section Technical information/Design tips, page 52-55.