





The company and the products

ETP Transmission AB have developed and manufactured hydraulic hub-shaft connections for more than 25 years, which are sold under the trademark ETP®. The company has built up a unique world wide knowledge within the hydraulic fastening and centering field.

Continuous development with customers has resulted in a steady flow of new products.

Electron beam welding is one of the key manufacturing operations, which gives the ETP-Product range its extreme levels of precision & repeatable performance.

The company has built up a leading position within three different business areas: general machine building (described in this brochure), industrial woodworking and metal machining.

Since 1995 the company is certified according to ISO 9001. Authorized representatives with stock and high levels of technical service are present in each country in Western Europe, North America, Japan, Australia, New Zealand, South-Africa, India and Southeast Asia.



Box 1120, SE-581 11 Linköping, Sweden
Tel. +46 (0)13 24 71 00, Fax +46 (0)13 14 47 08
E-mail: info@etptrans.se, Internet: www.etptrans.se

Pascal discovered the principle We put it to work

The scientist Blaise Pascal formulated the principle of pressure propagation in liquids many years ago:

"A liquid confined in a vessel which is subjected to pressure distributes the pressure uniformly upon the walls of the vessel."

ETP has explored the many positive qualities in this principle, developed it further and applied it to the hub-shaft connections.

"A hydraulic pressure medium confined in a double-walled sleeve is pressurized (with screws/pistons or with an external pump). The pressure is distributed evenly along and around hub/shaft. The double-walled sleeve expands uniformly and gives an even contact pressure against shaft and hub."

The ETP-Principle gives because of the hydraulic system: compact design, fast mounting, easy to position, good runout, does not damage the contact surfaces and is easy to dismantle. These qualities are important today and will be even more important in the future. With increasing requirements on down sizing the machines, better runout/balance, increased machine speeds, shorter downtime for service and increased precision, the ETP hydraulic hub-shaft connections are chosen for more and more designs.

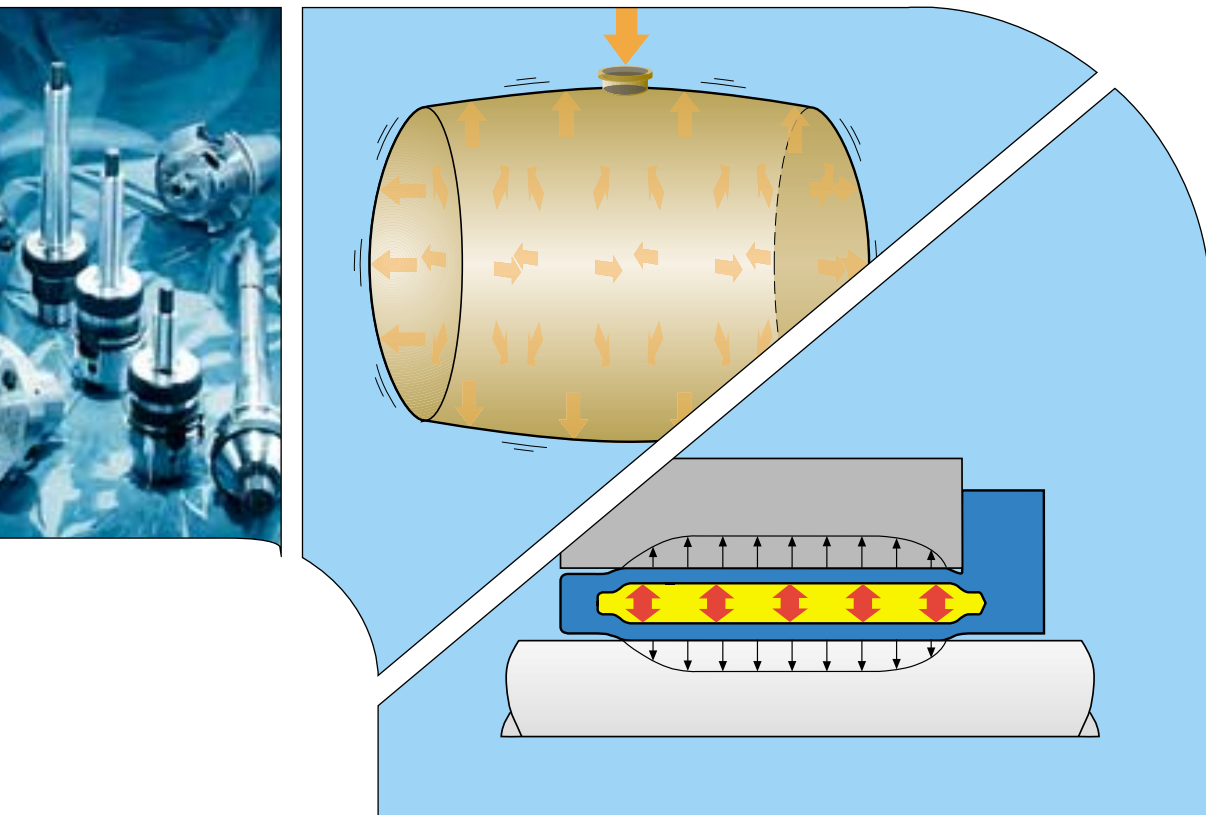

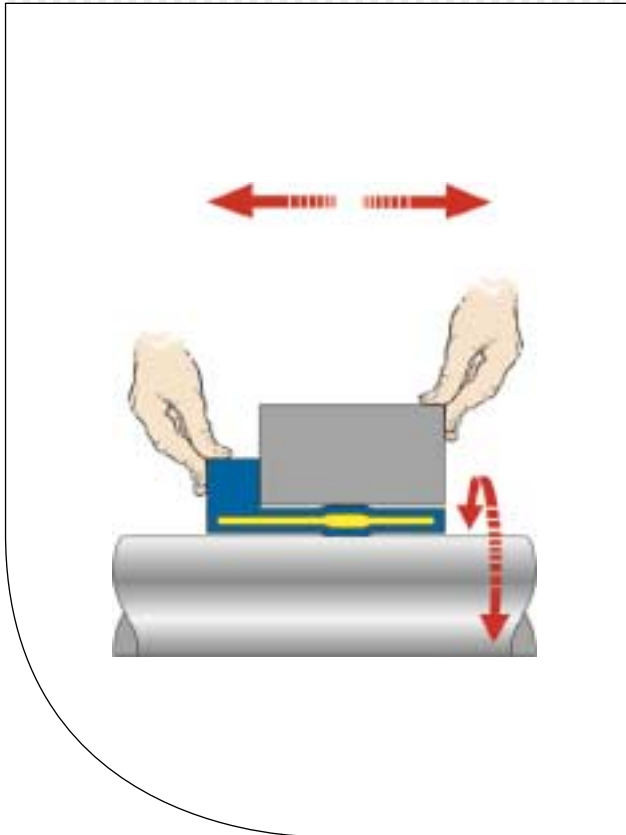

EASY AND ACCURATE TO POSITION

When starting the mounting/pressurizing, the double-walled sleeve will come in contact with the middle of the area on the hub and shaft first. In this situation it is still easy to turn, and axially move the ETP connection, around and along the shaft.

The hub is easy to position accurately in the required location and synchronize with other machine elements.

At continued pressurizing the double-walled sleeve only moves in the radial direction towards the hub and shaft, the adjusted position will be maintained. This means that time is saved as the mounting will be accurate and correct.

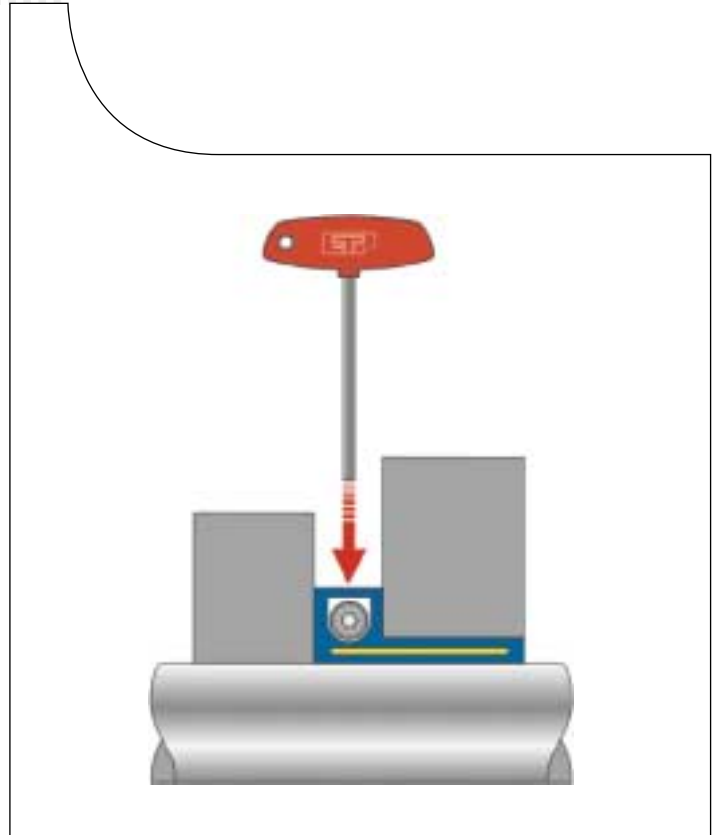

SAVES SPACE ALONG THE SHAFT

Some of the ETP connections have the pressure screw or hose connection in the radial direction to the shaft. When the connections are in the radial direction, no space needs to be reserved along the shaft for mounting tools. An advantage with this is, another machine component can be placed all the way up against the flange of the ETP connection.

The minimal space needed for the flange makes a very compact design possible.

All together this means reduced weight, smaller dimensions and lower polar moment of inertia for the final design.

The hydraulic ETP-principle gives advantages at design, manufacturing, mounting, operation and dismantling

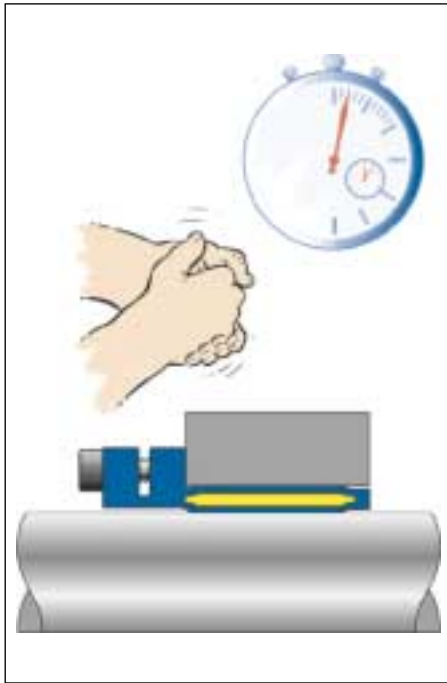

QUICK MOUNTING

Mounting of the hydraulic ETP connection is completed and ready within a few minutes. Only a few screws, for some ETP connections only one need to be tightened to a low tightening torque. The connection can immediately be subjected to a load. Tightening of the screws is not required afterwards. The contact length onto the hub and shaft is long, so that the surface pressure can be kept at a moderate level. The low and even surface pressure means that the hub and shaft surfaces will not be damaged. This means that hubs of aluminium can be used.

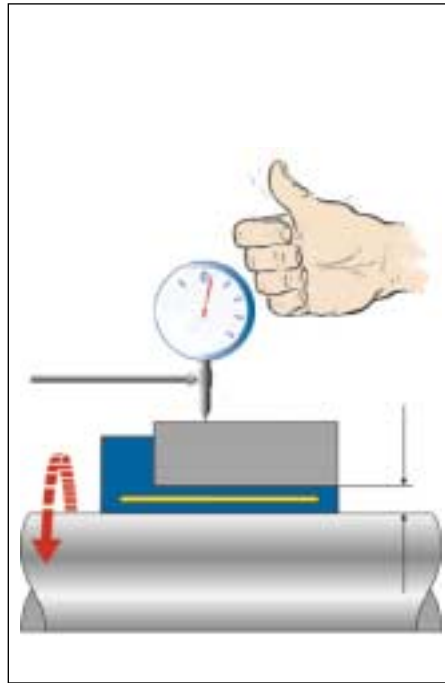

GOOD RUNOUT

The hydraulic principle coupled with our accurate machining, makes the runout (axial and radial) and balance extremely good. The surface pressure is equal both around and along the shaft and hub. This combined with the small built-in dimensions of the ETP connection means a small outer diameter of the hub. These qualities mean that the ETP connections give a minimum of unbalance at high rpm's.

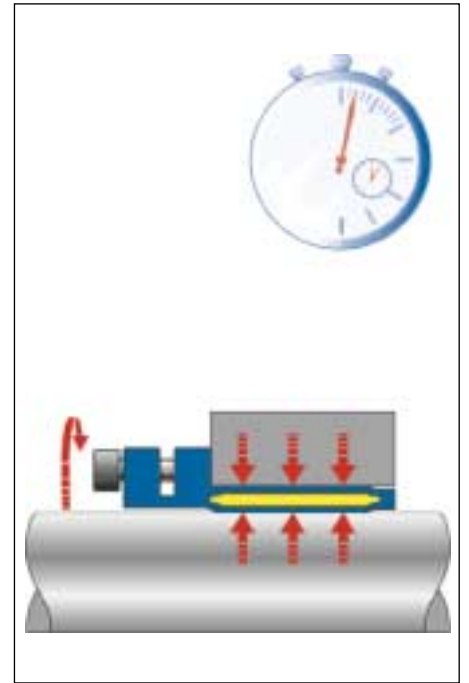

QUICK DISMANTLING

Dismantling the ETP connection, is as quick and easy as the mounting. When the screws are loosened, the hydraulic pressure reduces and disappears, the elastically pre-stressed double-walled sleeve returns to its original dimensions and can immediately be removed. The ETP connection can then be mounted as quick again, with the same good precision and performance as the first time. The downtime will be minimized.



- For all normal needs, mm and inch.
- Also in stainless.

- For fast mounting and compact design.
- Also in stainless.

- For extremely good concentricity.
- For frequent mounting.

- For small shafts, mm and inch.
- Also in stainless.

- For fast mounting and high loads.
- Good concentricity.

- Shrink joint for hollow shafts.
- Fast and accurate mounting.

- Torque wrenches, pumps.
- Connections, screws.
- Friction increasing methods.

- Design aids.
- Hub, tolerances, runout etc.
- Design tips.

- ETP-UNIGRIP, ETP-KN etc.



DNV

SS-EN ISO 9001



1053
EN 45012

QUALITY IN DESIGN AND MANUFACTURE

At ETP all are aware about their responsibility for quality. To ensure that our designs meet the customers requirements, we collaborate closely with our sub-contractors and leading customers. When developing new products these are validated together with customers.

Production is planned and controlled so that quality and environmental requirements are fully met while maintaining high productivity. Monitoring is systematic and continuous. The quality system complies with the SS-EN ISO 9001.

Choose the ETP-connection that suits you best

ETP-CLASSIC® incl. type R



Page
8-11

ETP-EXPRESS® incl. type R



Page
12-15

ETP-TECHNO®



Page
16-17

ETP-MINI™ incl. type R



Page
18-19

ETP-HYLOC®



Page
20-21

ETP-IMPRESS®

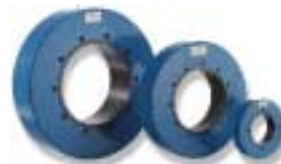

Page
22-23

ACCESSORIES



Page
24-26

TECHNICAL INFORMATION



Page
27-33

ETP-SPECIAL DESIGNS



Page
34-35

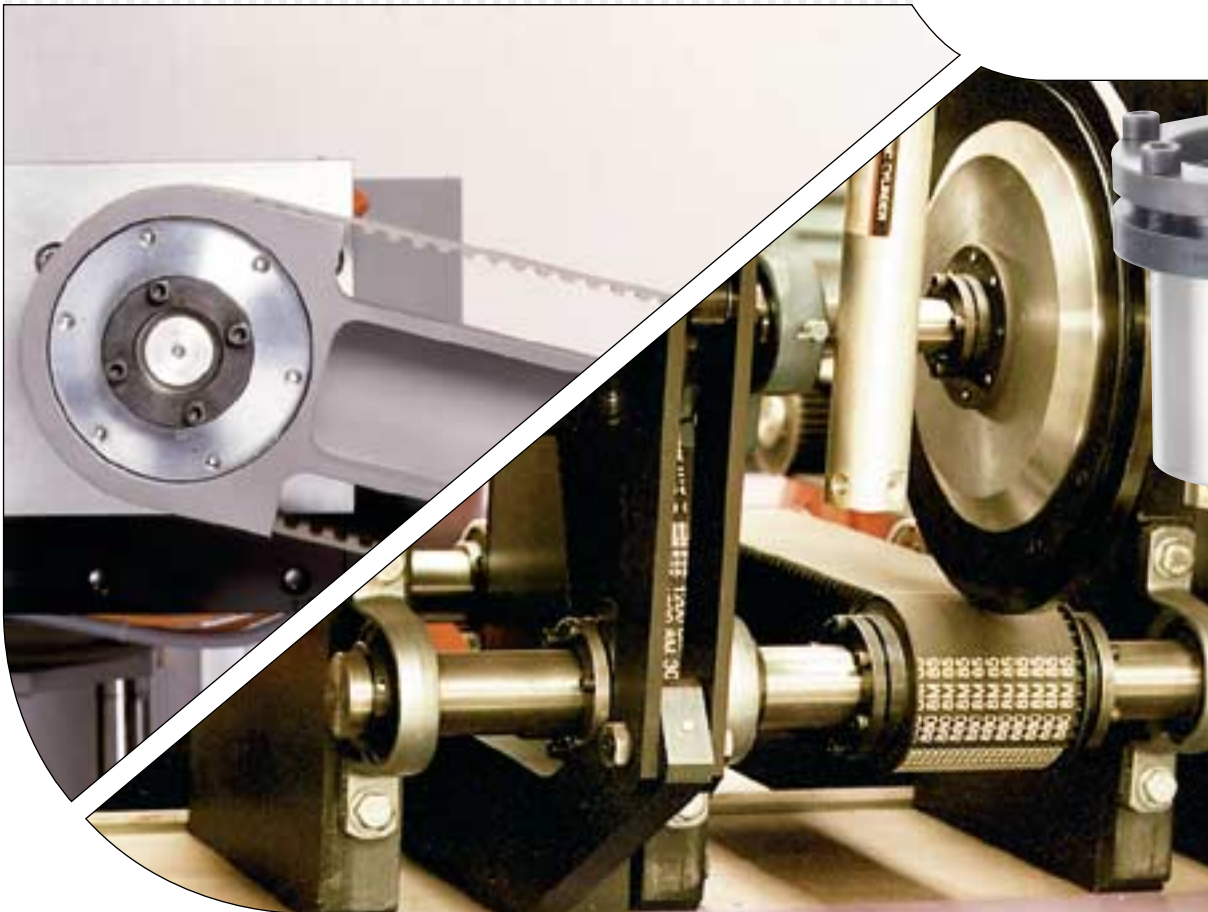

ETP-CLASSIC is used in a large variety of applications, for mounting timing belt pulleys, camcurves and arms etc. Positioning along and between the shafts is easy and fast with a high precision. Service and maintenance are also quick because of the easy dismantling. ETP-CLASSIC is recommended for all normal needs.

CONSTRUCTION

ETP-CLASSIC consists of a double-walled hardened steel sleeve filled with a specially adopted pressure medium, sealing ring, piston, pressure flange and clamping screws.

OPERATION

When tightening the screws, the sleeve expands uniformly against hub and shaft and creates a rigid joint. When loosening the screws the sleeve returns to its original measurements and can easily be dismantled.

QUALITIES

The unique hydraulic principle gives a great number of advantages:

- Small built-in dimensions and a reasonable surface pressure means small outside diameter for the hub.
- Mounting and dismantling is fast.
- Fine adjustment of the hub can be made during mounting.
- Low tightening torque and a small number of screws makes the mounting easy.
- Good concentricity, also after several mountings.
- ETP-CLASSIC has cap head screws but screws with hexheads can be used.

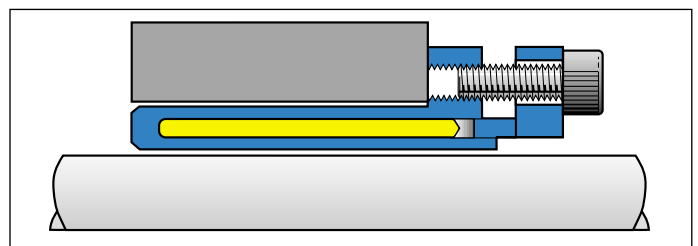

ETP-CLASSIC in place between the shaft and hub ready for mounting.

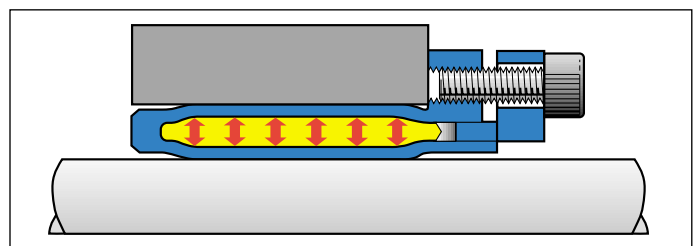

When the screws have been tightened, ETP-CLASSIC creates an even surface pressure against the hub and shaft along virtually the entire length.

ETP-CLASSIC®

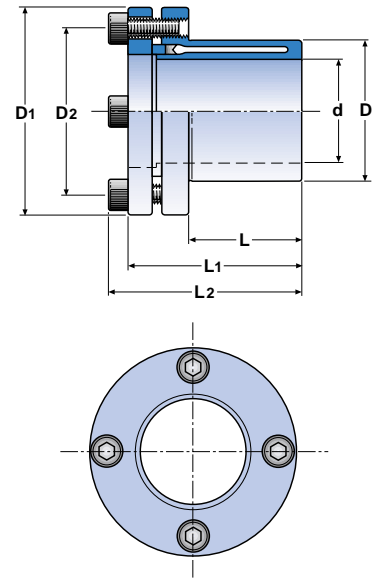

Notation ETP-CLASSIC XXX

ETP-CLASSIC	Dimensions							Transmittable torque or axial force		Screws DIN 912, 12.9			Polar moment of inertia J kgm ² • 10 ⁻³	Weight kg
	d mm	D mm	D ₁ mm	D ₂ mm	L mm	L ₁ mm	L ₂ mm	Tr Nm	Fr kN	No.	Dim.	Tt Nm		
15	15	23	38	28,5	17	30	35	55	7,3	3	M5	6	0,018	0,10
19	19	28	45	35	21	37	42	100	10,6	3	M5	8	0,046	0,17
20	20	28	45	35	22	37	42	125	12,5	3	M5	8	0,046	0,16
22	22	32	49	40	22	37	42	135	12,3	4	M5	8	0,065	0,19
24	24	34	49	40	25	40	45	200	16,7	4	M5	8	0,067	0,20
25	25	34	49	40	27	43	48	250	20,0	4	M5	8	0,071	0,19
28	28	39	55	46	29	45	50	300	21,4	4	M5	8	0,120	0,26
30	30	41	57	47,5	32	47	52	420	28,0	4	M5	8	0,142	0,29
32	32	43	60	50,5	34	52	57	420	26,3	4	M5	8	0,195	0,35
35	35	47	63	53,5	37	55	60	650	37,1	6	M5	8	0,250	0,40
38	38	50	65	56	41	59	64	750	39,5	6	M5	8	0,310	0,43
40	40	53	70	60,5	43	63	68	940	47,0	6	M5	8	0,441	0,55
42	42	55	70	60,5	45	65	70	940	44,8	6	M5	8	0,467	0,55
45	45	59	77	66,5	49	69	75	1290	57,3	6	M6	13	0,686	0,71
48	48	62	80	69,5	52	73	79	1570	65,4	6	M6	13	0,833	0,78
50	50	65	83	72,5	53	76	82	1900	76,0	6	M6	13	1,045	0,86
55	55	71	88	78	58	82	88	2500	90,9	8	M6	13	1,432	1,06
60	60	77	95	84,5	64	90	96	3400	113	8	M6	13	2,150	1,37
65	65	84	102	91	68	96	102	3500	108	8	M6	13	3,100	1,67
70	70	90	113	99	72	99	107	5200	149	6	M8	32	4,080	2,04
75	75	95	118	104	85	114	122	6300	168	6	M8	32	5,500	2,51
80	80	100	123	109	90	120	128	8800	220	6	M8	32	8,100	2,68
85	85	106	129	115	95	125	133	8800	207	6	M8	32	9,500	3,09
90	90	112	135	121	100	133	141	11000	244	8	M8	32	12,200	3,52
95	95	120	143	129	105	139	147	12800	269	8	M8	32	17,100	4,46
100	100	125	148	134	110	145	153	15500	310	8	M8	32	19,950	4,87

Tr= Transmittable torque when axial force is 0.
Fr= Transmittable axial force when torque is 0.
Tt= Recommended tightening torque for the screws.

} When the screws are tightened to Tt.

The dimensions are valid for ETP-CLASSIC before mounting.
Dimension subject to alterations without notice.

TOLERANCES

Shaft h8 – k6 (size 15 only h7)

Hub H7

For further information see the section for technical information and tolerances.

VERSIONS

Also available in a complete range of inch sizes 3/4" – 4", and in a shorter version for shafts 19 – 50 mm, see under the section for special designs.

Runout, balance, number of mountings, hub/hollow shaft, fatigue, temperature and radial loads/bending torque.

See the section for technical information.

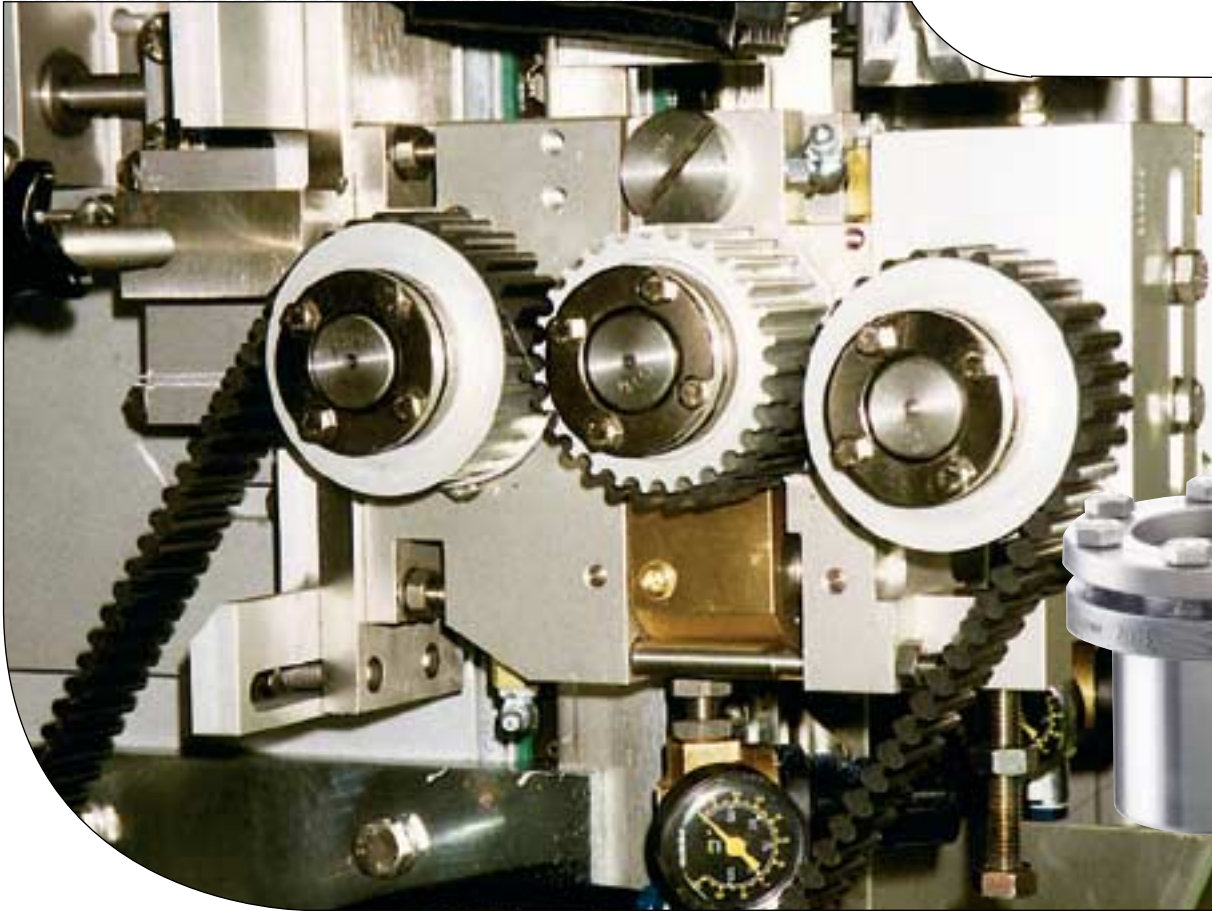

The demand from the food and process industries is increasing for stainless steel hub-shaft connections; surface coatings and plating are no longer sufficient. The most common sizes of ETP-CLASSIC are also available in stainless steel.

CONSTRUCTION

ETP-CLASSIC type R is the normal type of ETP-CLASSIC made of stainless steel. Type R has hexhead stainless steel screws, in order to facilitate easy cleaning when used for example in machines for processing food.

OPERATION

ETP-CLASSIC type R works in the same way as ETP-CLASSIC with a few exceptions:

- There are a few more screws in type R as the tightening torque is lower for stainless steel screws.
- It is designed for shaft tolerance of h9.
- The transmittable torque is lower.

QUALITIES

- ETP-CLASSIC type R has the same qualities as ETP-CLASSIC when it comes to fast/backlash free mounting and positioning.
- All parts exposed to the environment are made of stainless steel. In food processing this meets essential requirements.

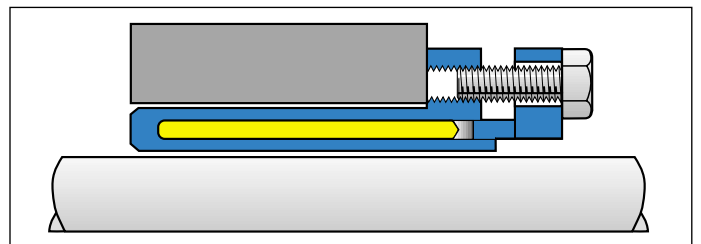

ETP-CLASSIC type R; in place between the shaft and hub ready for mounting.

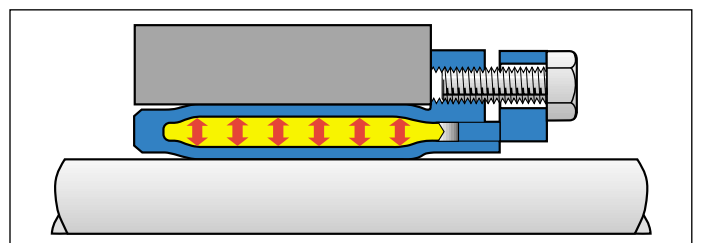

When the screws have been tightened ETP-CLASSIC will create an even surface pressure against the hub and shaft along virtually the entire length.

ETP-CLASSIC® R

NEW

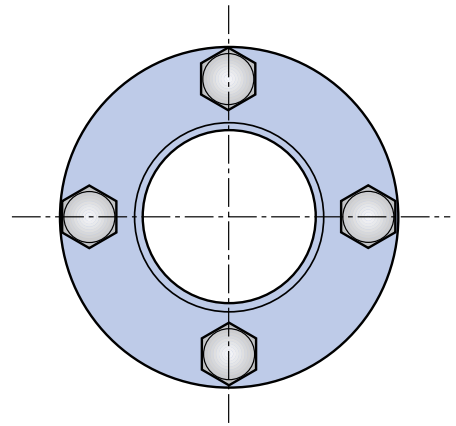
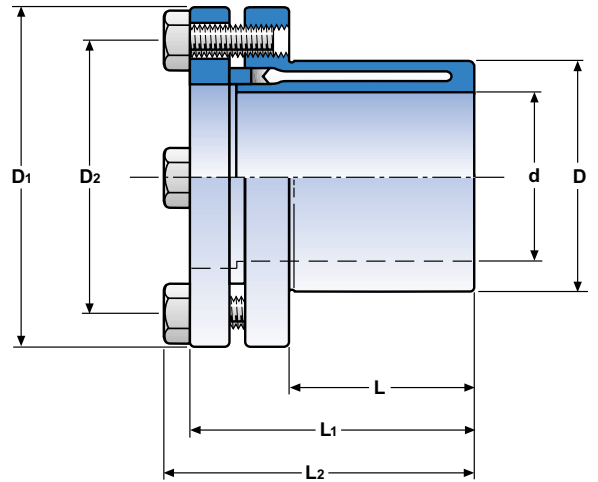

Notation ETP-CLASSIC R-XX

ETP-CLASSIC	Dimensions							Transmittable torque or axial force		Screws *)DIN 933, A4			Polar moment of inertia J $\text{kgm}^2 \cdot 10^{-3}$	Weight kg
	d mm	D mm	D ₁ mm	D ₂ mm	L mm	L ₁ mm	L ₂ mm	Tr Nm	Fr kN	No.	Dim.	Tt Nm		
R-15	15	23	38	28,5	17	30	34	45	6,0	4	M5	4,5	0,018	0,10
R-20	20	28	45	35	22	37	41	100	10,0	5	M5	4,5	0,046	0,16
R-25	25	34	49	40	27	43	46	210	16,8	7	M5	4,5	0,071	0,19
R-30	30	41	57	47,5	32	47	51	350	23,3	7	M5	4,5	0,142	0,29
R-35	35	47	63	53,5	37	55	59	500	28,5	9	M5	4,5	0,250	0,40
R-40	40	53	70	60,5	43	63	67	750	37,5	9	M5	4,5	0,441	0,55
R-45	45	59	77	66,5	49	69	73	1100	48,8	9	M6	7,8	0,686	0,71
R-50	50	65	83	72,5	53	76	80	1550	62,0	9	M6	7,8	1,045	0,86

Tr= Transmittable torque when axial force is 0.
Fr= Transmittable axial force when torque is 0.
Tt= Recommended tightening torque for the screws.

} When the screws are tightened to Tt.

The dimensions are valid for ETP-CLASSIC R before mounting.
Dimension subject to alterations without notice.

TOLERANCES

Shaft h8 (R-15 only h7)
Hub H7

For further information see under the section for technical information and tolerances.

MATERIAL

Double-walled sleeve: 420 S 37, stainless steel.

Screws: DIN 933, A4.

*)Surface treated for a low and even friction in the threads.

MOUNTING ADVICE

Make sure that the screw threads are well lubricated (OKS 260 or Molykote D) before each mounting.

Runout, balance, number of mountings, hub/hollow shaft, fatigue, temperature and radial loads/bending torque.
See the section for technical information.



ETP-EXPRESS has only one screw for pressurising, it is therefore specially designed for when there is a need for the repositioning of the hub to be done fast and accurately. The screw is tightened in the radial direction, this means that no space is used along the shaft for mounting tools. Other components can be mounted on the shaft all the way up to the flange. ETP-EXPRESS has extremely small built-in dimensions.

CONSTRUCTION

ETP-EXPRESS consists of a double-walled hardened steel sleeve and flange filled with a pressure medium. The flange part contains a screw and piston with seals to maintain pressure.

OPERATION

When the pressure screw is tightened the double-walled sleeve expands uniformly against shaft and hub and creates a rigid joint. Dismantling is done by loosening the screw. ETP-EXPRESS returns to its original dimensions and can easily be dismantled.

QUALITIES

The unique hydraulic principle gives a great number of advantages:

- Extremely fast mounting/dismantling with only **ONE screw**.
- Radial tightening of the screw saves space along the shaft.
- Extremely small built-in dimensions.
- Accurate positioning, no axial movement when mounting.
- Good concentricity, also after several mountings.

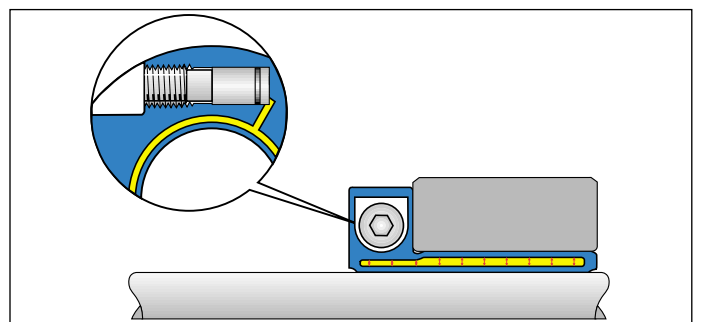

When the pressure screw is tightened to the recommended tightening torque, the piston has reached the bottom of the bore. ETP-EXPRESS has created a uniform surface pressure against the shaft and hub.

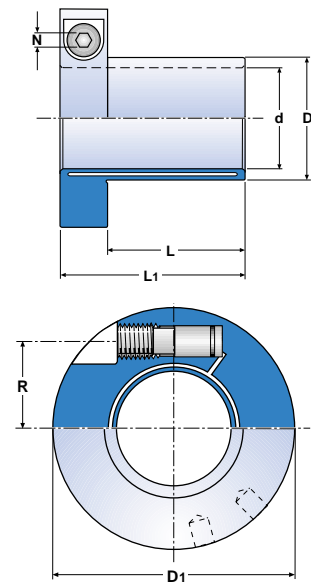

Notation ETP-EXPRESS XX

ETP-EXPRESS	Dimensions					Transmittable			Screws DIN 915, 12.9				Polar moment of inertia J $\text{kgm}^2 \cdot 10^{-3}$	Weight kg
	d mm	D mm	D ₁ mm	L mm	L ₁ mm	torque Tr Nm	axial force Fr kN	radial force Fr kN	Dim	R mm	N mm	Tt Nm		
15	15	18	46	25	39	46	6,1	0,5	M10	15,1	5	5	0,043	0,16
5/8"	15,875	19	47	26	40	53	6,7	0,5	M10	15,6	5	5	0,047	0,17
19	19	23	50,5	28	42	85	8,9	1	M10	17,4	5	5	0,064	0,20
3/4"	19,05	23	50,5	28	42	85	8,9	1	M10	17,4	5	5	0,064	0,20
20	20	24	51,5	30	44	110	11	1	M10	18	5	5	0,070	0,21
22	22	27	55,5	32	46	130	11	1,2	M10	19,3	5	5	0,097	0,25
24	24	29	57,5	33	47	190	15	1,4	M10	20,3	5	5	0,112	0,27
25	25	30	58	35	49	230	18	1,5	M10	20,8	5	5	0,117	0,27
1"	25,4	31	59	35	49	190	15	1,5	M10	21,2	5	5	0,127	0,29
28	28	34	63	38	52	280	20	1,8	M10	22,6	5	5	0,170	0,34
30	30	36	64,5	40	54	380	25	2	M10	23,6	5	5	0,189	0,35
1 1/4"	31,75	39	68,5	42	56	430	27	2,2	M10	24,8	5	5	0,249	0,42
32	32	39	68,5	42	56	440	27	2,2	M10	24,8	5	5	0,249	0,42
35	35	42	73	45	59	640	36	2,5	M10	26,4	5	5	0,325	0,48
38	38	46	84,5	52	72	890	46	2,8	M16	31	8	21	0,761	0,84
1 1/2"	38,1	46	84,5	52	72	890	46	2,8	M16	31	8	21	0,761	0,84
40	40	48	86,5	55	75	1100	55	3	M16	32	8	21	0,844	0,88
42	42	51	89	56	76	1100	52	3,2	M16	33,2	8	21	0,971	0,96
45	45	54	93	58	78	1400	62	3,5	M16	34,8	8	21	1,170	1,05
48	48	59	97	59	79	1700	70	4	M16	36,8	8	21	1,458	1,21
50	50	60	98,5	60	80	1900	76	4,5	M16	37,5	8	21	1,524	1,20
2"	50,8	61	101,5	60	80	1900	74	4,5	M16	38	8	21	1,716	1,28
55	55	67	106	65	85	2400	87	5	M16	40,5	8	21	2,182	1,50
60	60	73	115,5	70	90	3300	110	5,3	M16	43,3	8	21	3,167	1,85
70	70	85	135,5	85	109	5600	160	6,4	M20	50,8	10	39	7,125	3,04
80	80	97	145,5	95	119	8700	210	7,5	M20	56,3	10	39	10,350	3,75

Tr= Transmittable torque when axial force is 0.
 Fr= Transmittable axial force when torque is 0. } When the screw is tightened to Tt.
 Fr= Max transmittable radial force.
 Tt= Recommended tightening torque for the screw.

Dimensions subject to alterations without notice.

TOLERANCES

Shaft h7 for d=15 mm.
 Shaft h8 for d= 5/8", 3/4", 20, 25, 1", 30, 1 1/4", 35, 1 1/2", 40, 45, 50, 2", 60, 70, 80 mm.
 Shaft k6-h7 for d= 19, 22, 24, 28, 32, 38, 42, 48, 55 mm.
 Hub H7.
 For further information see under the section for technical information and tolerances.

TIGHTENING TORQUE

When the tightening torque, Tt, is reached the piston is at the end of the bore. Further turning does not increase pressure.

Runout, balance, number of mountings, hub/hollow shaft, fatigue, temperature and radial loads/bending torque.
 See the section for technical information.



The demand from the food and process industries is increasing for stainless steel hub-shaft connections; surface coatings and plating are no longer sufficient. The most common sizes of ETP-EXPRESS are also available in stainless steel.

CONSTRUCTION

ETP-EXPRESS type R is the normal ETP-EXPRESS made of hardened stainless steel. The screw is also stainless.

OPERATION

ETP-EXPRESS type R works in the same way as ETP-EXPRESS.

QUALITIES

- ETP-EXPRESS type R has the same good qualities when it comes to fast and frequent mounting with only **ONE screw** in the radial direction, small built-in dimensions etc. as ETP-EXPRESS.
- All parts of ETP-EXPRESS R exposed to the environment are made of stainless steel.
- Easy to clean. In food processing this meets essential requirements.

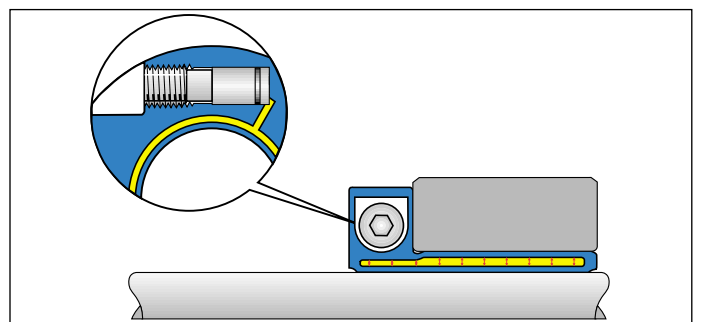

When the pressure screw is tightened to the recommended tightening torque, the piston has reached the bottom of the bore. ETP-EXPRESS type R will have created a uniform surface pressure against the shaft and hub.

NEW

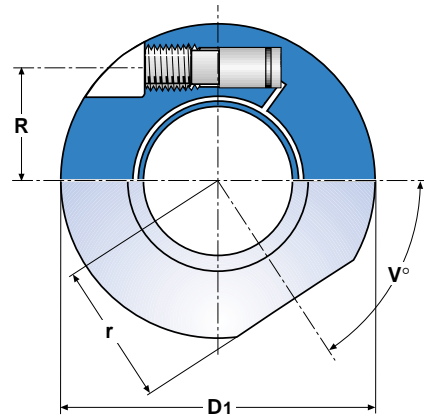
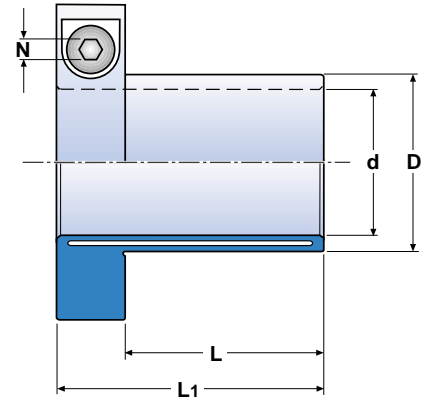

Notation ETP-EXPRESS R-XX

ETP-EXPRESS	Dimensions							Transmittable			Screw *)DIN 915, A4				Polar moment of inertia J kgm ² • 10 ⁻³	Weight kg
	d mm	D mm	D ₁ mm	L mm	L ₁ mm	r mm	V°	torque Tr Nm	axial force Fr kN	radial force Fr kN	Dim.	R mm	N mm	Tt Nm		
R-15	15	18	46	25	39	19,9	53	46	6,1	0,5	M10	15,1	5	5	0,043	0,16
R-20	20	24	51,5	30	44	22,6	56	110	11	1	M10	18	5	5	0,070	0,21
R-25	25	30	58	35	49	25,8	58	230	18	1,5	M10	20,8	5	5	0,117	0,27
R-30	30	36	64,5	40	54	29,1	59	380	25	2	M10	23,6	5	5	0,189	0,35
R-35	35	42	73	45	59	33,7	58	640	36	2,5	M10	26,4	5	5	0,325	0,48
R-40	40	48	86,5	55	75	37,7	59	1100	55	3	M16	32	8	21	0,844	0,88
R-45	45	54	93	58	78	41,1	59	1400	62	3,5	M16	34,8	8	21	1,170	1,05
R-50	50	60	98,5	60	80	43,7	60	1900	76	4,5	M16	37,5	8	21	1,524	1,20

Tr= Transmittable torque when axial force is 0. } When the screw is tightened to Tt.
 Fr= Transmittable axial force when torque is 0.
 Fr= Max transmittable radial force.
 Tt= Recommended tightening torque for the screw.

Dimensions subject to alterations without notice.

TOLERANCES

Shaft h8 (R-15 only h7).
 Hub H7.

For further information see under the section for technical information and tolerances.

MATERIAL

Double-walled sleeve: 431 S 29, stainless steel.

Screw: DIN 915, A4.

*)Surface treated for a low and even friction in the threads.

MOUNTING ADVICE

Make sure that the screw thread is well lubricated (OKS 260 or Molykote D) before each mounting.

Runout, balance, number of mountings, hub/hollow shaft, fatigue, temperature and radial loads/bending torque.
 See the section for technical information.

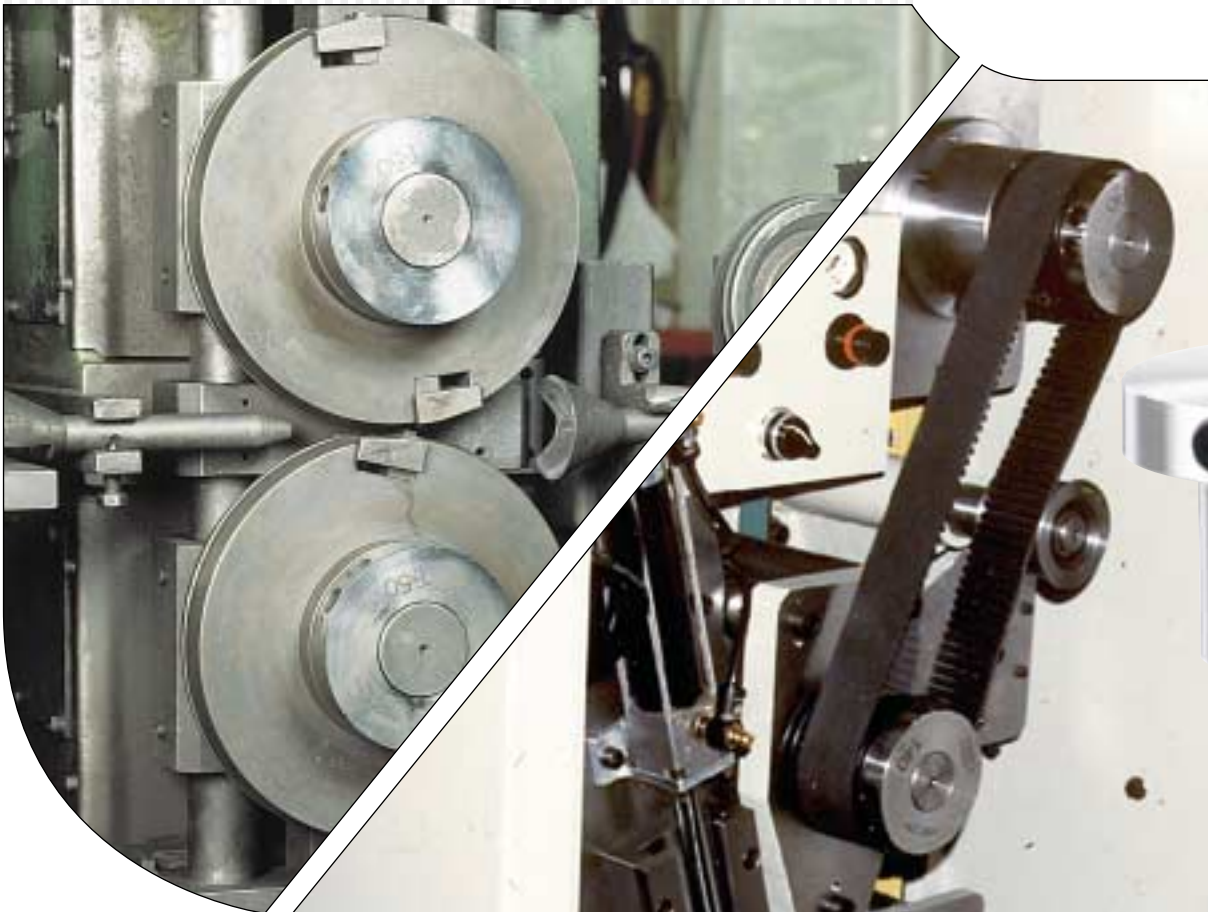

ETP-TECHNO is specially designed for applications where fast frequent changes or adjustments, with high precision are needed. ETP-TECHNO can be mounted/dismantled 1000's of times. It is very easy to mount ETP-TECHNO in a tight space, and it also has extremely good concentricity. ETP-TECHNO is the high precision joint among the ETP hub-shaft connections.

CONSTRUCTION

ETP-TECHNO consists of a double-walled hardened steel sleeve and flange filled with a pressure medium. The flange part contains the pressurizing mechanism which consists of a screw and piston with double sealing function, an o-ring and a metallic seal with a steel ball which is pressed against a spherical seating.

The outer, D, and inner, d, diameter and the side of the flange towards the hub are accurately machined for extremely good concentricity.

The piston and the cylinder are designed for 1000's of mountings.

OPERATION

When the pressure screw is tightened the double-walled sleeve expands uniformly against the shaft and the hub thus creating a rigid joint. Dismantling of the joint is done by loosening the screw. ETP-TECHNO returns to its original measurements and can easily be dismantled.

QUALITIES

The unique hydraulic principle gives a great number of advantages:

- Fast mounting/dismantling. Only one screw needs to be tightened.
- Extremely good concentricity, also after several mountings.
- Can be mounted/dismantled 1000's of times.

- Possible to mount in tight spaces. The pressure screw is tightened in the radial direction to the shaft.
- Small built-in dimensions.
- The hub can be adjusted easily and accurately.

ETP-TECHNO is also suitable as a base for customer adapted solutions. See the section for ETP-Special designs.

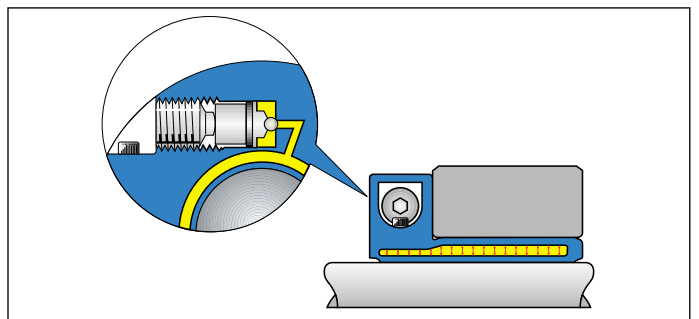

When the pressure screw is tightened to the recommended tightening torque, T_t , the steel ball seals against the spherical seating. ETP-TECHNO will have created a uniform surface pressure against the shaft and hub.

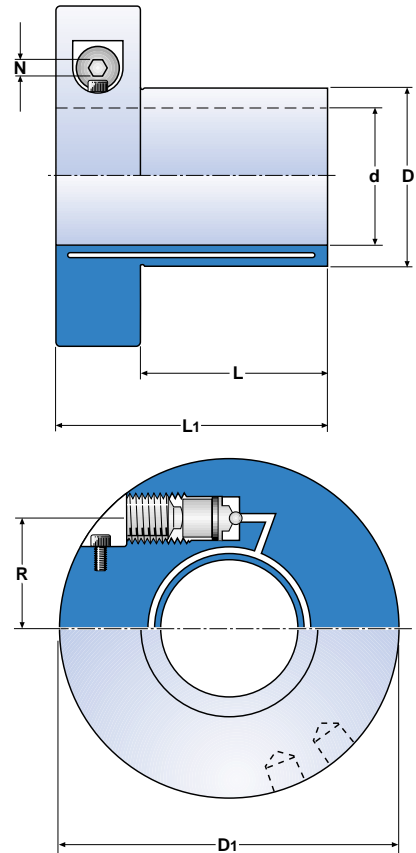

Notation ETP-TECHNO XXX

ETP-TECHNO	Dimensions					Transmittable			Screws				Polar moment of inertia J $\text{kgm}^2 \cdot 10^{-3}$	Weight kg
	d mm	D mm	D ₁ mm	L mm	L ₁ mm	torque Tr Nm	axial force Fr kN	radial force Fr kN	Dim	R mm	N mm	Tt Nm		
15	15	19	52	25	41	40	5	1	M12	16	6	10	0,092	0,25
20	20	25	59	30	46	120	12	2	M12	19	6	10	0,153	0,32
25	25	32	70	35	55	290	23	3	M14	24	6	16	0,382	0,58
30	30	38	76	40	60	500	33	4	M14	26,5	6	16	0,541	0,69
32	32	41	79	42	62	600	37	4	M14	27,5	6	16	0,641	0,78
35	35	44	82	45	65	800	45	5	M14	29	6	16	0,752	0,84
40	40	52	92	55	75	1200	60	6	M16	33,5	8	24	1,267	1,18
45	45	56	96	58	78	1550	68	7	M16	35,5	8	24	1,503	1,24
50	50	65	105	60	80	2000	80	9	M16	39,5	8	24	2,313	1,62
60	60	75	122	70	95	4000	133	12	M20	46,5	10	40	5,027	2,51
70	70	90	136	85	110	6500	186	13	M20	52,5	10	40	8,854	3,65
75	75	95	146	90	115	7800	208	14	M20	56	10	40	11,600	4,20
80	80	100	154	95	120	9000	225	15	M20	58	10	40	14,370	4,77
90	90	112	170	105	133	13000	288	17	M22	65	10	60	24,062	6,48
100	100	125	184	115	145	18000	360	19	M24	72	12	80	37,013	8,41

Tr= Transmittable torque when axial force is 0.
Fr= Transmittable axial force when torque is 0. } When the screw is tightened to Tt.
Fr= Max transmittable radial force.
Tt= Recommended tightening torque for the screw.

Dimensions subject to alterations without notice.

TOLERANCES

Shaft h8.

Hub H7.

For further information see under the section for technical information and tolerances.

TIGHTENING TORQUE

When the tightening torque, Tt, is reached the piston is at the end of the bore. Further tightening does not increase pressure.

Runout, balance, number of mountings, hub/hollow shaft, fatigue, temperature and radial loads/bending torque.

See the section for technical information.

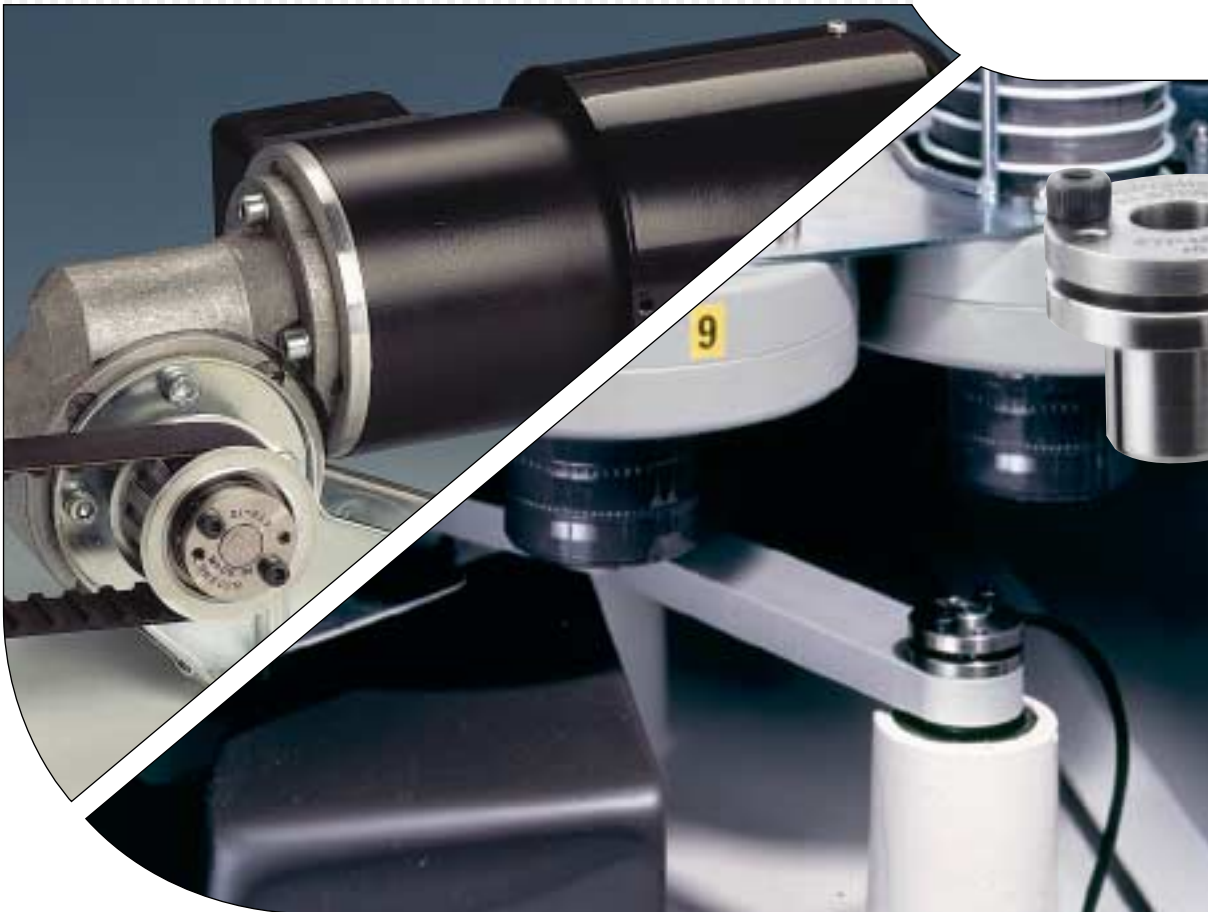

ETP-MINI is far superior to keyways or setscrews because it allows an adjustable, backlash free joint. Typical applications are mounting of hubs on small electrical motors, steppermotors and encoders. As no keyways are needed, the shaft will not be weakened and the unbalance will be lower, which is very important at high speeds, as the motor bearing are sensitive to vibrations. Also available in stainless, ETP-MINI type R, suitable for the food processing industry etc.

CONSTRUCTION

ETP-MINI consists of two, partly slotted, conical steel sleeves (type R stainless) and clamping screws (type R stainless).

OPERATION

By tightening the screws the inner sleeve is pressed against the shaft and the outer sleeve against the hub thus forming a rigid joint.

When dismantling, one or if necessary, two of the screws are moved to the threaded dismantling holes in the flange. By tightening, the sleeves will separate and the joint will loosen.

ETP-MINI type R has one screw more than the normal ETP-MINI in order to transmit the same torque (lower tightening torque for stainless screws). The built-in dimensions are the same.

QUALITIES

- Easy to mount.
- Transmits high torque.
- Allows wide tolerances.
- Available in stainless steel (type R).

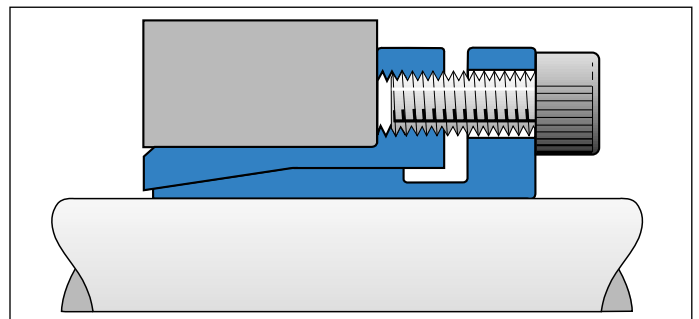

The inner sleeve, for ETP-MINI incl. type R, has a light recess close to the flange in order to create a more uniform surface pressure to the shaft.

NEW



ETP-MINI™ incl. type R

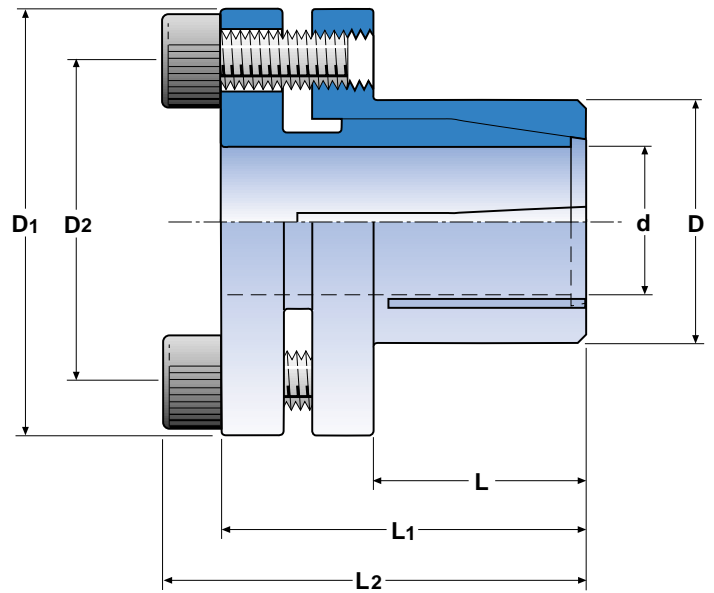

Notation ETP-MINI XX

ETP-MINI	Dimensions							Transmittable torque or axial force		Screws DIN 912, 12.9			Polar moment of inertia J kgm ² • 10 ⁻⁶	Weight kg
	d mm	D mm	D ₁ mm	D ₂ mm	L mm	L ₁ mm	L ₂ mm	Tr Nm	Fr kN	No.	Dim.	Tt Nm		
6	6	14	25	18	10	19	22	5	1,7	2	M3	2	2,1	0,03
1/4"	6,35	14	25	18	10	19	22	6	1,7	2	M3	2	2,1	0,03
8	8	15	27	20	12	21,5	25,5	17	4,4	2	M4	4	3,3	0,04
9	9	16	28	21	14	24	28	20	4,4	2	M4	4	4,4	0,05
3/8"	9,525	16	28	21	14	24	28	22	4,4	2	M4	4	4,4	0,05
10	10	16	28	21	14	24	28	23	4,4	2	M4	4	4,3	0,05
11	11	18	30	23	14	25,5	29,5	25	4,4	2	M4	4	6,2	0,06
12	12	18	30	23	14	25,5	29,5	27	4,4	2	M4	4	6,1	0,06
1/2"	12,7	18	30	23	14	25,5	29,5	29	4,4	2	M4	4	6,0	0,06
14	14	22	35	27	15	27,5	31,5	48	6,5	3	M4	4	13,2	0,08

Tr= Transmittable torque when axial force is 0. } When the screws are tightened to Tt.
 Fr= Transmittable axial force when torque is 0. }
 Tt= Recommended tightening torque for the screws.

The dimension are valid for ETP-MINI before mounting.
 Dimensions subject to alternations without notice.

Notation ETP-MINI R-XX

ETP-MINI	Dimensions							Transmittable torque or axial force		Screws *)DIN 912, A4			Polar moment of inertia J kgm ² • 10 ⁻⁶	Weight kg
	d mm	D mm	D ₁ mm	D ₂ mm	L mm	L ₁ mm	L ₂ mm	Tr Nm	Fr kN	No.	Dim.	Tt Nm		
R-6	6	14	25	18	10	19	22	5	1,7	3	M3	1,2	2,1	0,03
R-8	8	15	27	20	12	21,5	25,5	17	4,4	3	M4	2,7	3,3	0,04
R-10	10	16	28	21	14	24	28	23	4,4	3	M4	2,7	4,3	0,05
R-12	12	18	30	23	14	25,5	29,5	27	4,4	3	M4	2,7	6,1	0,06
R-14	14	22	35	27	15	27,5	31,5	48	6,5	4	M4	2,7	13,2	0,08

Tr= Transmittable torque when axial force is 0. } When the screws are tightened to Tt.
 Fr= Transmittable axial force when torque is 0. }
 Tt= Recommended tightening torque for the screws.

The dimension are valid for ETP-MINI R before mounting.
 Dimensions subject to alternations without notice.

TOLERANCES

Shaft: k6-h10.

Hub: H8.

For further information see under the section for technical information and tolerances.

MATERIAL FOR TYPE R

Double-walled sleeve: 303 S 31, stainless steel.

Screws: DIN 912, A4.

*)Surface treated for a low and even friction in the threads.

MOUNTING ADVICE

Make sure that the screw threads for type R are well lubricated (OKS 260 or Molykote D) before each mounting.

Runout, balance, number of mountings and hub/hollow shaft.

See the section for technical information.

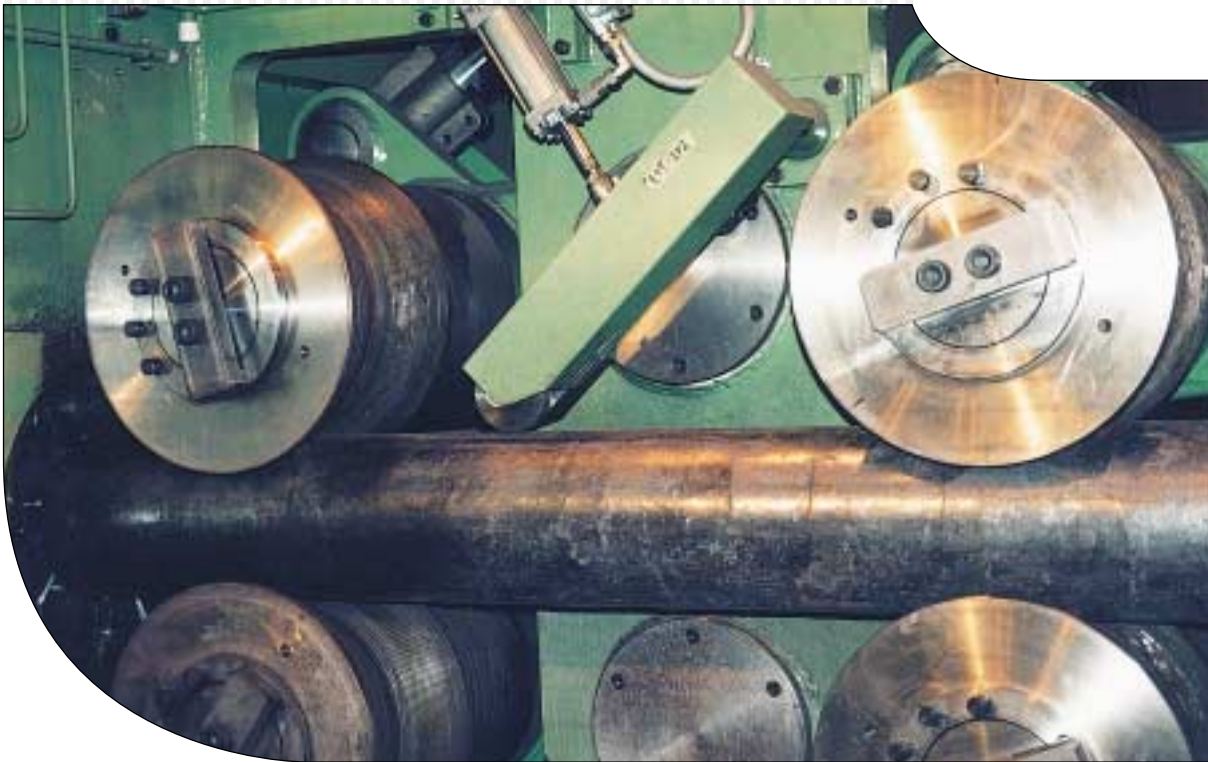

ETP-HYLOC, due to its robust design, is ideally suited to work in difficult environments and heavy operations like steel rolling mills, process industry etc. An interesting application, among many, has been fastening of rolls to shafts. ETP-HYLOC is fast to mount, has good concentricity and can take high radial loads.

CONSTRUCTION

ETP-HYLOC is a hydromechanical joint, which consists of a double-walled steel sleeve which encloses a conical moveable piston. In the flange there are three threaded connections ("ON", "P" and "OFF") in the radial direction and the same in the axial. This makes it possible to choose radial or axial connection of the hoses. Mounting and dismantling is carried out with a hydraulic pump.

OPERATION

When the piston is moved, by the hydraulic pressure from the pump, the double-walled sleeve expands uniformly against shaft and hub to form a rigid joint.

When dismantling, the piston is moved in the opposite direction and the joint will loosen.

A small amount of oil will be taken via spiral tracks in the piston between the surfaces (pressure applied through the "P" connection), in this way making it easier for the piston to move.

QUALITIES

- High transmittable torque which can be varied by changing the mounting pressure.
- Fast mounting/dismantling in tight spaces. By using a pump the time is reduced to a minimum even for large sizes.
- Radial and axial connection is possible.
- Fine adjustments of the hub can be made when mounting.
- Good concentricity, also after several mountings.
- High radial load capacity.

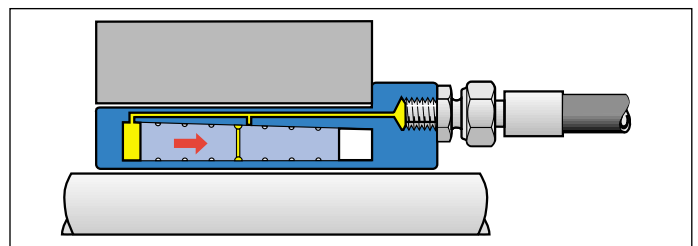

Mounting: Apply pressure in the "ON" and "P" (not shown) connections. When mounted no hydraulic pressure remains. The small conical angle prevents the piston from releasing.

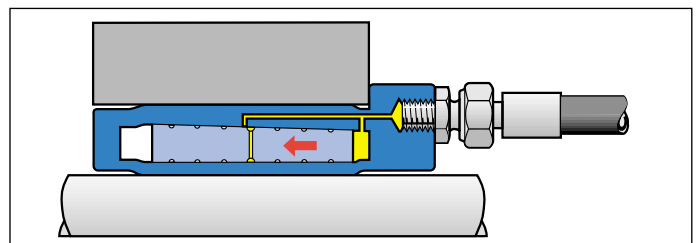

Dismantling: Apply pressure in the "OFF" and "P" (not shown) connections. ETP-HYLOC returns to its original measurements and the joint is loose.



ETP-HYLOC®

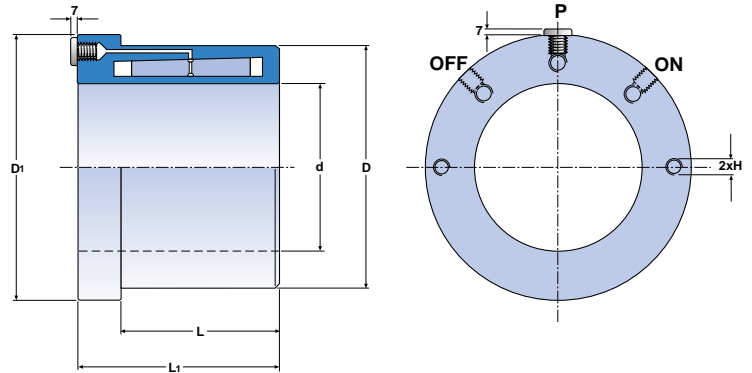

ETP-HYLOC is prepared for axial connection of the hoses (where the plastic plugs are situated). If radial connection is to be made, the steel plugs are moved to the axial connections and are tightened with a torque wrench to 20 Nm.

Axial/radial connections G 1/8.

Notation: ETP-HYLOC XXX

ETP-HYLOC	Dimensions					Transmittable torque or axial force		Min. hub D _H mm	H	Polar moment of inertia J kgm ² • 10 ⁻³	Weight kg
	d mm	D mm	D ₁ mm	L mm	L ₁ mm	Tr Nm	Fr kN				
50	50	77	101	57	82	2600	104	105	M8	3,2	2,4
60	60	89	113	65	90	4600	153	125	M8	5,4	3,1
70	70	102	122	75	100	7900	226	145	M8	8,7	4,1
80	80	115	135	85	110	12100	303	160	M8	14	5,4
90	90	128	148	95	120	17100	380	180	M12	23	7,0
100	100	140	160	105	130	24200	484	200	M12	34	8,6
110	110	154	173	115	140	32900	598	220	M12	51	11
120	120	168	186	125	150	43200	720	240	M12	76	14
130	130	182	200	135	160	53800	828	260	M16	110	17
140	140	196	213	145	170	68900	984	280	M16	150	21
150	150	210	227	155	180	85400	1139	300	M16	210	25
160	160	224	240	165	190	104000	1300	320	M16	290	30
180	180	252	267	185	210	150000	1667	360	M16	500	42
200	200	280	293	205	230	206000	2060	400	M16	830	56
220	220	308	320	225	250	273000	2482	435	M16	1300	73

Tr= Transmittable torque when axial force is 0. } When the mounting pressure is 1000 bar and shaft tolerance h7. H: Threads for easy handling.
 Fr= Transmittable axial force when torque is 0. } Dimension subject to alterations without notice.
 D_H= Min. outer diameter for hubs of steel with yieldpoint >400 N/mm².

ETP-HYLOC	800 bar				1000 bar				1200 bar			
	Tr Nm	Min. hub D _H		Tr Nm	Min. hub D _H		Tr Nm	Min. hub D _H				
		Yieldpoint N/mm ² >300	>400		Yieldpoint N/mm ² >300	>400		Yieldpoint N/mm ² min 400	>400			
50	1600	95	90	2400	110	105	3100	130				
60	3000	120	110	4300	140	125	5600	155				
70	5300	140	125	7400	170	145	9500	170				
80	8400	165	140	11500	200	160	14600	190				
90	11800	185	160	16200	235	180	20600	215				
100	17100	210	180	23100	270	200	29200	235				
110	23500	235	195	31500	295	220	39600	260				
120	31100	255	215	41600	320	240	52000	280				
130	38100	275	230	51400	350	260	64700	305				
140	49600	295	250	66200	375	280	82900	325				
150	61900	315	265	82300	400	300	102000	350				
160	76000	335	285	100000	425	320	125000	370				
180	110000	375	320	146000	480	360	181000	415				
200	151000	420	355	200000	535	400	248000	465				
220	201000	460	390	266000	585	435	330000	510				

Valid for shaft tolerance h8.

TOLERANCES

Shaft h7 (for h8 see table)

Hub H7

For further information see under the section for technical information and tolerances.

MOUNTING – ADVICE

The contact surfaces L and L₁ must be completely covered by the shaft and hub.

The oil for the pump should be a transmission oil type 80 W. For pumps/connections see under section accessories.

MOUNTING PRESSURE

The mounting pressure is normally 1000 bar. Max mounting pressure 1200 bar.

Note! The minimum outer diameter of the hub, D_H, must then be increased (see table).

Dismantling requires max. 200 bar higher pressure than for mounting.

VERSIONS

Larger sizes available, see page 34. ETP-HYLOC can be designed to suit special applications on request.

Runout, balance, number of mountings, hub/hollow shaft and radial loads/bending torque. See the section for technical information.

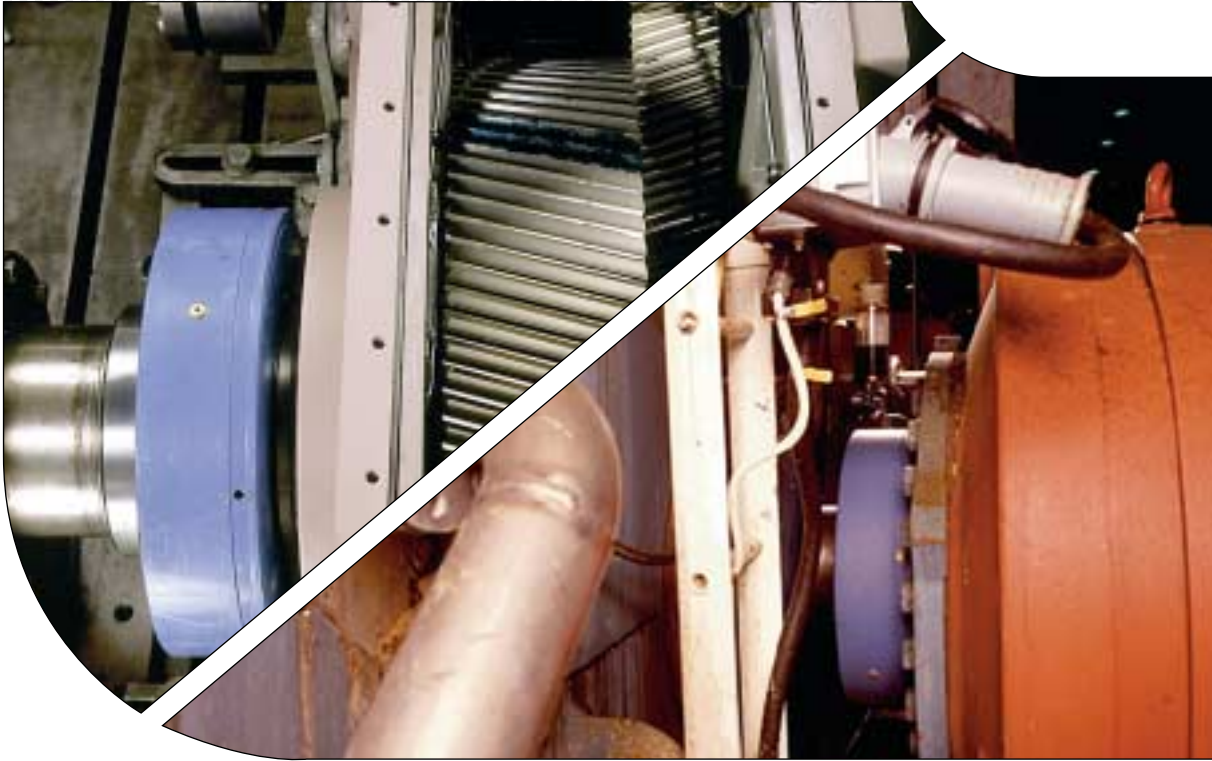

The connection of a hollow shaft, for example from a hydraulic motor or a gearbox, to a shaft is today often done with a mechanical shrink disc. These are built up of conical rings. When mounting a high radial force is needed to compress both the conical rings and the hollow shaft. This is achieved through a lot of screws with a high tightening torque. Mounting/dismantling causes long downtime which is expensive in the process industry for example in the pulp and paper industry. ETP-IMPRESS is a shrink connection where the mounting and dismantling is done easily and quickly through hydraulic pressure.

CONSTRUCTION

ETP-IMPRESS consists of two flange parts and an inner sleeve with two or more conical surfaces, connections for hydraulic are both radial (RC) and axial (AC), locking screws (LS), dismantling screws (DS) and seals.

OPERATION

The sealed chamber between the flanges is pressurised with a hydraulic pump. The pressure makes the flanges move apart in the axial direction, the conical surfaces will then press the inner sleeve uniformly against the hollow shaft. The hollow shaft will be compressed and engage the solid shaft. A surface pressure will be built up between the hollow shaft and the solid shaft. When the mounting pressure is reached the axial locking screws are tightened. The hydraulic pressure is released; the flanges will stay in position supported by the locking screws. The connection is ready.

When dismantling, the joint is pressurized; the locking screws loosened, the pressure released and the connection is free. Because of the friction resistance around the seals it may be necessary to use the radial dismantling screws for loosening ETP-IMPRESS from the hollow shaft.

QUALITIES

The unique hydraulic principle gives a great number of advantages.

- Mounting/dismantling is done quickly, easily and accurately.
- Can be mounted/dismantled a great number of times without servicing.
- Can be mounted in tight spaces.
- Is possible to dismantle without hydraulic.
- Approx. same built-in dimensions as mechanical joints.
- Direct relation between hydraulic pressure and transmittable torque.
- No large screws with high tightening torque for mounting, which have a high-risk breaking.

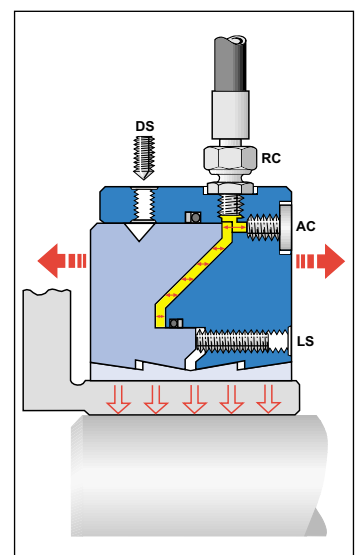

Mounting is done in a couple of minutes with hydraulic, even on large hollow shafts. Dismantling is as quick.

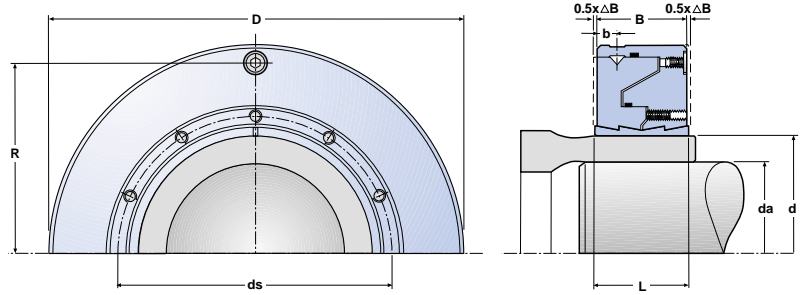

Notation ETP-IMPRESS XXX

ETP-IMPRESS	Dimensions					Transmittable torque or axial force		Max. width B+ΔB mm	Mounting pressure bar	Locking screws DIN 913, HRC 45			Axial connection R mm	Dismantling screws, 4 pcs		Max. oil volume l	Weight kg
	d mm	da mm	D mm	L mm	B mm	Tr Nm	Fr kN			No.	Dim.	ds mm		Dim.	b mm		
100	100	70	195	40	38	10700	308	43,3	250	4	M10	124	82	M4	7,3	0,05	6
		75				12300	330										
		80				14100	354										
125	125	85	235	50	46	20800	491	52,6		6	M10	151	102	M6	10,6	0,10	11
		90				23500	523										
		95				26100	550										
		100				29000	580										
165	165	115	295	60	56	49100	854	64,5		7	M12	196	132	M6	13,2	0,21	20
		120				53500	891										
		125				58000	928										
185	185	135	340	80	76	96200	1426	85,5		10	M12	219	154,5	M10	15,1	0,36	37
		140				103500	1479										
		145				111000	1531										
200	200	150	355	80	76	113200	1510	85,9		11	M12	236	162	M10	16,6	0,39	39
		155				120800	1560										
		160				128700	1610										
240	240	170	435	100	94	179300	2110	105,8		9	M16	286	199,5	M10	18,4	0,70	74
		180				201100	2235										
		190				224100	2359										
260	260	190	455	120	114	213000	2243	127,3	350	12	M16	312	207	M10	19,9	0,75	95
		200				236000	2360										
		210				260200	2479										

Tr= transmittable torque when axial force is 0. } At the mounting pressure acc. to above
Fr= transmittable axial force when torque is 0. }

Other sizes are available on request.
Dimensions subject to alteration without notice.

TOLERANCES

da (mm)	Tolerances, da	
	Solid shaft	Hollow shaft inside (mm)
70 - 80	h6	+0,004 to +0,034
85 - 120	h6	+0,004 to +0,039
125 - 160	h6	+0,004 to +0,044
170 - 210	g7	H8

Outer diameter hollow shaft, d = h8.

MOUNTING

Mounting pressure acc. to above. Same for dismantling. All types of hydraulic oil can be used. Clean the contact surfaces between hollow/solid shaft thoroughly.

MAX. STROKE, ΔB

ΔB can be reached by largest possible play within the prescribed tolerances.

BUILT-IN

The contact area L must be covered by both the hollow shaft and the solid shaft mounted in the hollow shaft, before pressurizing.

CONNECTIONS

Axial and radial pump connections, G 1/8, 180° apart.

LOCKING SCREWS

The locking screws are tightened to approx. 5 Nm, before the pressure is released. All the screws should be tightened equally.

HYDRAULIC PUMPS

See the accessories section. Max. oil volume acc. to above refers to max. stroke, ΔB.

LOADS

Torque and axial forces are calculated for a hollow shaft of nodular iron (E=160 000

MPa). Friction Coefficient, μ, between solid shaft and hollow shaft of 0,15 (well cleaned surfaces).

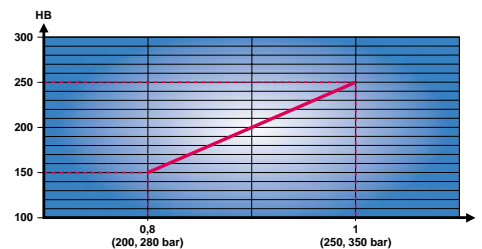

If the hardness of the hollow shaft is < 250 HB the surface might be damaged. This can be avoided by reducing the mounting pressure. The transmittable torque will then be proportionally reduced. For example a hardness of 150 HB, a reduction of the mounting pressure by 20% is recommended.

ETP-CLASSIC incl. type R ETP-MINI incl. type R



To facilitate the use of the ETP hub-shaft connections there are specially designed torque wrenches, hex head screws in class 12.9 (normally not a standard product) and adapters for these.

HEX HEAD SCREWS

For ETP-CLASSIC there are hex head screws DIN 933, quality 12.9, as accessories. These can be used when space in the axial direction is limited.

TORQUE WRENCHES

The torque wrenches have been designed for ETP-CLASSIC and ETP-MINI incl. the R types. They have a fixed torque which releases with a "snap" at the recommended tightening torque, T_t . The torque wrench makes the mounting easier and guarantees a correct tightening.

It is equipped with an adapter which fits the corresponding screws for the ETP connection. For ETP-CLASSIC there is an adapter for hex head screws as an accessory, in case the screws have been changed.

Torque wrench	Torque (Nm)	Adapter for hex head	For size
M06	6	A08	15
M08	8	A08	19 – 42
M13	13	A10	45 – 65
M32	32	A13	70 – 100
MR4,5	4,5	Standard	R-15 – R-40
MR7,8	7,8	Standard	R-45 – R-50

Torque wrenches for ETP-CLASSIC incl. type R.

Torque wrench	Torque (Nm)	For size
M02	2	6 – 1/4"
M04	4	8 – 14
MR1,2	1,2	R-6
MR2,7	2,7	R-8 – R-14

Torque wrenches for ETP-MINI incl. type R.

ETP-TECHNO ETP-EXPRESS incl. type R



The torque wrenches are specially designed to facilitate the use of the ETP connections and assure a correct tightening.

SCREWS

All pressure screws for ETP-TECHNO and ETP-EXPRESS incl. type R have cap heads. These are available as spare parts.

TORQUE WRENCHES

The torque wrenches are designed for ETP-TECHNO and ETP-EXPRESS incl. type R. They are equipped with wratch head and snap function when the fixed torque (recommended tightening torque, T_t) is reached. The hex head key is integrated in a specially designed adapter which facilitates handling and accessibility.

Torque wrench	Torque (Nm)	For size
M10	10	15 – 20
M16	16	25 – 35
M24	24	40 – 50
M40	40	60 – 80
M60	60	90
M80	80	100

Torque wrenches for ETP-TECHNO

Torque wrench	Torque (Nm)	For size
M05	5	15 – 35
M21	21	38 – 60
M39	39	70 – 80

Torque wrenches for ETP-EXPRESS incl. type R

Accessories

ETP-HYLOC



Quick connection
type 01.

Quick connection
type 02.

Quick connection
type 03.

QUICK CONNECTIONS

When ETP-HYLOC needs to be mounted frequently and fast, the hoses can be equipped, as accessories, with special high-pressure quick release chucks. The ON, P, and OFF connections for ETP-HYLOC are then equipped with the corresponding nipples.

There are the following 3 versions:

Type 01: the chuck is "pulled" side ways over the nipple.

Type 02: the chuck is screwed onto the nipple with an outer ring.

Type 03: the chuck is pressed on to the nipple. This type has bigger built-in dimensions and can not be used axially, if the shaft pass all the way through, for sizes ≤ 110 mm.

3 nipples are needed for each ETP-HYLOC and for each pump 3 chucks. A quick connection consists of one chuck (C) and one nipple (N), for example type 01 of C-01 and N-01.



Handpump H-11 is delivered in a practical steel box.



Motorpump A-03, pneumatically driven.

HYDRAULIC PUMPS

The pumps are designed for ease of use at the pressures and volumes that are needed for ETP-HYLOC.

The handpump H-11 is a robust, CE marked, pump.

Motorpump A-03 is designed to be used when mounting frequently.

Both pumps are equipped with manometer and 3 hoses (length 3 m), 2 high-pressure hoses and a thinner hose for the return oil. A threaded connection G 1/8 is on each hose which is suitable for ETP-HYLOC.

Max. pressure 1 500 bar.

ETP-IMPRESS



Handpump H30.

HYDRAULIC PUMP

The pump capacity and handling is designed for the oil volumes and pressures needed for all sizes of ETP-IMPRESS (100 to 260 mm).

It is delivered with manometer and hose (length 2 m), hose connection G 1/8. Max. pressure 400 bar. Oil volume for the pump 1 l. Equipped with an overflow connection for larger return flows.

Friction increasing methods

In certain applications high even loads or high peak loads occur, which would cause the ETP hub-shaft connection to slip. To overcome this problem some ETP products have been developed which increases the coefficient of friction, μ , and therefore the transmittable torque and axial force. The enlarged drawings below illustrate the various products. The bore surface of the ETP hub-shaft connection is shown in blue, the shaft in grey.

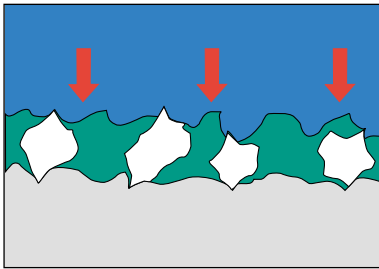

ETP-FRICTION

ETP-FRICTION is a liquid containing extremely small, hard, irregular particles which "grips into" the contact surfaces. It is easily applied with a brush or cloth. ETP-FRICTION will not harden or cure.

Content in the can: 125 ml.

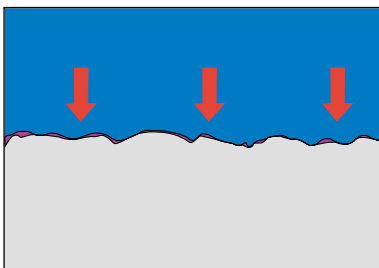

ETP-INTERFIX®

ETP-INTERFIX is a specially developed anaerobic adhesive which fills the irregularities in the surfaces. When hardened ETP-INTERFIX forms a layer of approx. 0,002 mm.

Content in the bottle: 10 gram.

Some premachining of the inner- and outer diameter of the ETP hub-shaft connection is necessary to make sure that dismantling is possible. Instruction is included.

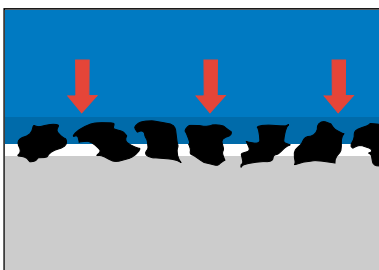

ETP-HFC

ETP-HFC (High Friction Coating) is a surface treatment of the bore and outside diameter of the ETP hub-shaft connection. ETP-HFC is a carbide coating of small, sharp particles which are imbedded into the treated surface. Is offered separately.

TRANSMITTABLE TORQUE CAPACITY

Untreated ETP hub-shaft connection = 1.

Torque duty	ETP-FRICTION	ETP-INTERFIX	ETP-HFC
Static	2	2-3	2
Pulsating	2	2-3	2
Alternating	Not suitable	2-3	2

For applications with a large number of load cycles (more than 10 000 times) at an increased torque level, there is a risk of fatigue in the ETP product. Please contact us to confirm your application.

The friction increasing methods for ETP hub-shaft connections are all easily dismantled. ETP-FRICTION and ETP-INTERFIX must be reapplied before remounting.

The methods only work for locking assemblies with unslotted sleeves. They have only been tested on ETP hub-shaft connections.

Information on our homepage

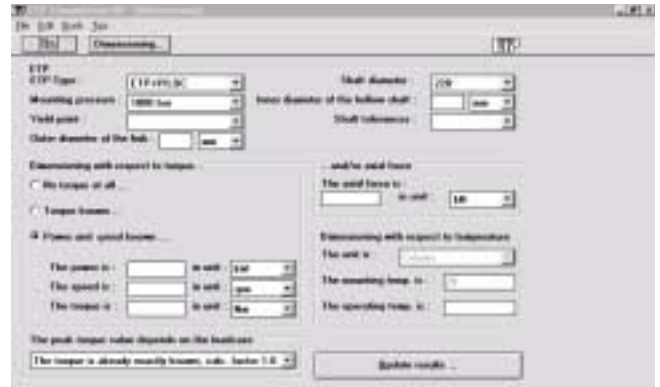
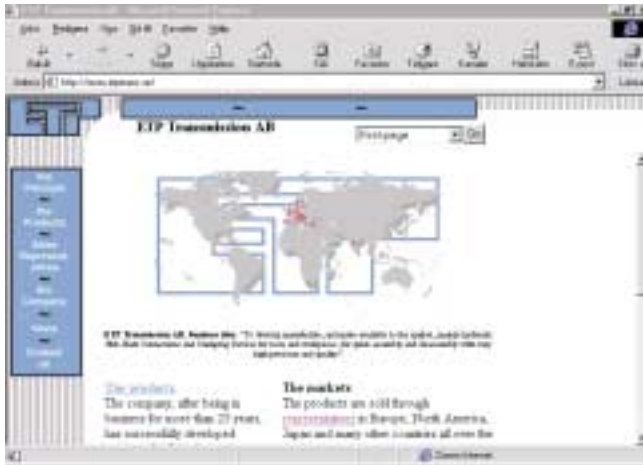

Our homepage contains among other things updated product information, information about new products as well as design and calculation support material

ADDRESS

The homepage address is: <http://www.etptrans.se> or <http://www.etpinc.com>.

CONTENT

On the page there is information about the company, the products and links to most of the ETP representatives.

SELECTION PROGRAM

To facilitate the selection of the correct size of ETP connection there is a dimensioning program on the homepage, see example above. This can be downloaded from the page and used. It can also be sent on diskette upon request.

CAD SYMBOLS

To facilitate the design work there are CAD symbols in the form of side and front views and 3D-view for most of the ETP connections ready to be downloaded. They are made for AutoCAD and can be taken home in DWG or DXF format. They can also be sent on diskette upon request.

Transmittable torque

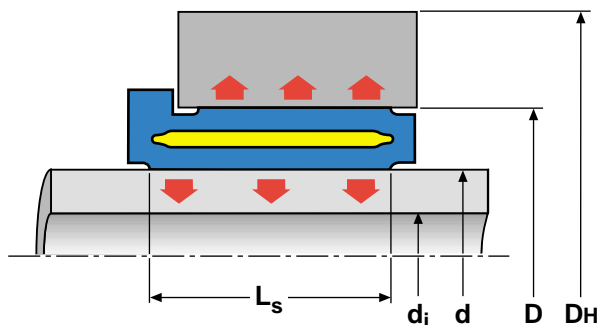

Principle built-in of an ETP connection.

The ETP connections are tubular and create a surface pressure on the shaft and the hub. By the friction resistance both axial forces and torques can be transmitted. The amount will be determined by the area of the contact surface, the surface pressure and the coefficient of friction (μ).

The following formula is valid:

$$T_r = p_s \cdot \frac{\pi d^2}{2} \cdot L_s \cdot \mu$$

L_s = the contact length

p_s = surface pressure on the shaft

p_H = surface pressure on the hub

Axial force

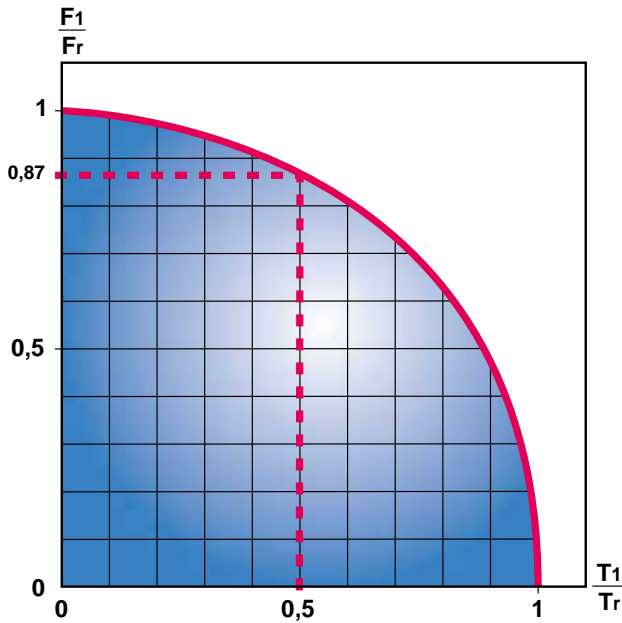

If axial force (F_1) and torque (T_1) are to be transmitted at the same time, the following formula is valid.

$$\left(\frac{F_1}{F_r}\right)^2 + \left(\frac{T_1}{T_r}\right)^2 \leq 1$$

this means that the value should be inside the quarter circle in the diagram.

F_r and T_r are the rated values for axial force and torque for the different ETP products.

Coefficient of friction (μ)

Recommended surface finish, shaft/hub	
Ra max	3,0 (μm)
Ra min	1,0 (μm)

Typical values for the coefficient of friction μ , steel to steel			
grease	oil (thin)	solvent	stainless
0,05	0,12	0,17	0,20

The coefficient of friction (μ) depend on a number of factors. The most important are:

SURFACE FINISH

The surface must not be too smooth. If it is, the influence of impurities can be great. A good turning operation is often better than grinding.

CLEANLINESS

It is very important that the surfaces are clean. Therefore we recommend to clean the contact surfaces thoroughly with a solvent before mounting.

Surface pressure

Max. tightening torque (screw quality 12.9)		
M5	M6	M8
10 Nm	17 Nm	40 Nm

If the tightening torque for ETP-CLASSIC is increased by 20 % the transmittable torque increases by 25 %.

Note: This effect can only be used if the operating temperature < the mounting temperature.

If the surface pressure is too low, a metallic contact between the surfaces will not be created because of oxide layers. If the surface pressure is too high, plastic deformation can occur and the friction will decrease dramatically. The hydraulic ETP principle gives a surface pressure within the right range, which is also utmost even around and along the contact area.

The surface pressure from the ETP connections (not ETP-HYLOC or ETP-IMPRESS) is at the recommended tightening torque:

p_s = approx. 90 N/mm².

p_H = approx. 70 N/mm².

By increasing the surface pressure the transmittable torque can be increased, see table.

Tolerances

Change of torque when ETP-CLASSIC is mounted on:		
h9 shaft	h8 shaft	k6 shaft
- 25 %	acc. to techn. data	+ 20 %

Recommended tolerances for shaft and hub are given under the section for each product.
If the tolerance differs from these so the play between the contact surfaces is increased. The surface pressure and the torque will decrease. The opposite is valid for decreased play. See example in the table.

Shaft tolerances in μm (upper/lower limits)					
Shaft dia.	k6	h7	h8	h9	h10
(3) – 6	+9/+1	0/-12	0/-18	0/-30	0/-48
(6) – 10	+10/+1	0/-15	0/-22	0/-36	0/-58
(10) – 18	+12/+1	0/-18	0/-27	0/-43	0/-70
(18) – 30	+15/+2	0/-21	0/-33	0/-52	0/-84
(30) – 50	+18/+2	0/-25	0/-39	0/-62	0/-100
(50) – 80	+21/+2	0/-30	0/-46	0/-74	0/-120
(80) – 120	+25/+3	0/-35	0/-54	0/-87	0/-140
(120) – 180	+28/+3	0/-40	0/-63	0/-100	0/-160
(180) – 250	+33/+4	0/-46	0/-72	0/-115	0/-185

Hub tolerances in μm (upper/lower limits)		
Hub dia.	H7	H8
(10) – 18	+18/0	+27/0
(18) – 30	+21/0	+33/0
(30) – 50	+25/0	+39/0
(50) – 80	+30/0	+46/0
(80) – 120	+35/0	+54/0
(120) – 180	+40/0	+63/0
(180) – 250	+46/0	+72/0
(250) – 315	+52/0	+81/0

Dimensioning of hub and hollow shaft

For ETP-HYLOC and ETP-IMPRESS see information under the corresponding product section, the information below is not valid for these.

Because of the even and reasonable surface pressure and the compact built-in dimensions of the ETP connections, a thin material in hub and shaft can be used. Also aluminium can be used.

For hubs and hollow shafts in steel, the yield point of those decides the thickness of the material. For cast iron and aluminium the module of elasticity is decisive.

The requisite thickness can be selected from the table or

more accurately in the diagram.

R_{eL} = Yield point for the material.

E = Module of elasticity.

D_N = The minimum outer diameter of the hub.

d_i = The maximum inner diameter of the hollow shaft.

σ = Effective stress.

For other notations see figure on page 27.

If $D_H/D < 1,4$ for the hub or if $d_i/d > 0,6$ for the hollow shaft, contact us for advice.

HUB

Material	D_H/D
Steel incl. stainless, $R_{eL} > 300 \text{ N/mm}^2$	1,4
Steel incl. stainless, $R_{eL} > 220 \text{ N/mm}^2$	1,5
Cast iron, $E = 120 \text{ kN/mm}^2$	2,0
Aluminium, $E = 70 \text{ kN/mm}^2$	2,5

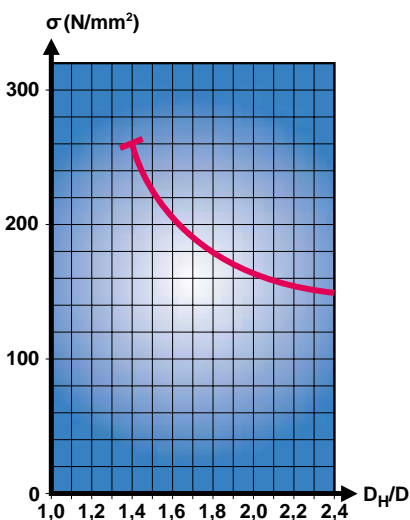

HOLLOW SHAFT

Material	d_i/d
Steel incl. stainless, $R_{eL} > 300 \text{ N/mm}^2$	0,6
Steel incl. stainless, $R_{eL} > 240 \text{ N/mm}^2$	0,5
Cast iron, $E = 120 \text{ kN/mm}^2$	0,3
Aluminium, $E = 70 \text{ kN/mm}^2$	0,2

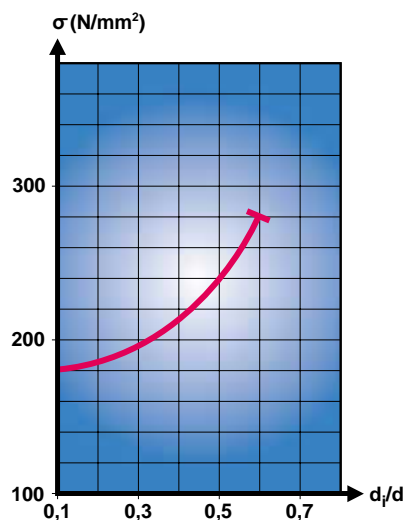

Runout and balance

The hydraulic ETP principle assures a good runout and balance. All products are designed balanced. For guide values see the table.

To these values the runout/unbalance for shaft and hub in the actual case has to be added in order to get the final value when mounted.

Dynamic balancing can be done on request.

	ETP-CLASSIC incl. type R	ETP-EXPRESS incl. type R	ETP-TECHNO	ETP-MINI incl. type R	ETP-HYLOC
Runout (mm)*	0,03 – 0,06	0,02	0,006	0,02	0,01 – 0,02
Unbalance (gmm/kg)	100	75	50	100	75**

* Values are also valid after several mountings.

** For size ≤ 100 mm, with radial mounted steel plugs, the unbalance is larger.

Number of mountings

ETP connection	Nbr. of mountings
ETP-CLASSIC	100
ETP-CLASSIC R	50
ETP-EXPRESS	1000
ETP-EXPRESS R	200
ETP-TECHNO	5000
ETP-MINI	100
ETP-MINI R	50
ETP-HYLOC	2000
ETP-IMPRESS	200

One of the qualities with the ETP connections are their ability to be mounted quickly and repeatedly with maintained performance and precision.

There is however a limit when the screw/screws will be worn and has to be changed. If the threads are cleaned and regularly lubricated the guide values in the table can be used.

The values indicates when the screws needs to be changed (the ETP connection lasts longer) for ETP-CLASSIC, ETP-EXPRESS, ETP-MINI incl. the R types and ETP-TECHNO.

For the R types it is very important that the screws are well lubricated when tightening both for proper function and full lifetime capabilities. When used in food processing applications or similar we recommend the lubricants OKS 260 or Molykote D. For other applications Molykote G-n plus can be used.

The value for ETP-IMPRESS indicates when it needs to be dismantled for lubrication of the tapered surfaces. We recommend Molykote G-Rapid plus.

ETP-HYLOC is not recommended for more mountings than acc. to the table.

Fatigue

ETP connection	Alternating	Pulsating
ETP-CLASSIC incl. type R: 15 – 30 mm	0,6	0,7
ETP-CLASSIC incl. type R: 32 – 100 mm	0,5	0,6
ETP-EXPRESS incl. type R	0,5	0,6
ETP-TECHNO	0,7	0,8

Fatigue effects all materials sooner or later that are subjected to loads incl. friction joints.

When the loads are in form of alternating or pulsating torque it is recommended to reduce the transmittable torque, T_r , with the factors according to the table (factor $\cdot T_r$). The values are based on tests and calculations on the lifetime of ETP connections.

The lifetime for the ETP connection increases if the play between the contact surfaces is decreased, for example ETP-CLASSIC can be used on a shaft tolerance of k6, instead of the recommended h8.

ETP-MINI and ETP-HYLOC can take essentially higher fatigue loads. The fatigue loads do not affect ETP-IMPRESS as they go through the hollow shaft.

Radial loads and bending torque

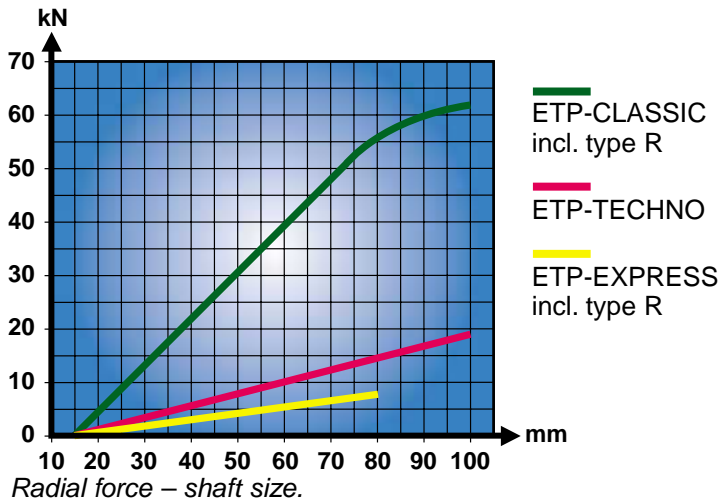

Most friction joints have a limited capacity to transmit radial forces and bending torque. Extreme levels of these loads can affect the function of the ETP connection. The values acc. to the diagram and table based on tests can serve as guide lines. ETP-MINI and ETP-HYLOC can transmit essentially higher radial forces than the other connections.

	ETP-CLASSIC incl. type R	ETP-EXPRESS incl. type R	ETP-TECHNO	ETP-MINI incl. type R	ETP-HYLOC
Bending torque as % of transmittable torque, T_r , acc. to technical data	15	5	10	30	15

Temperature

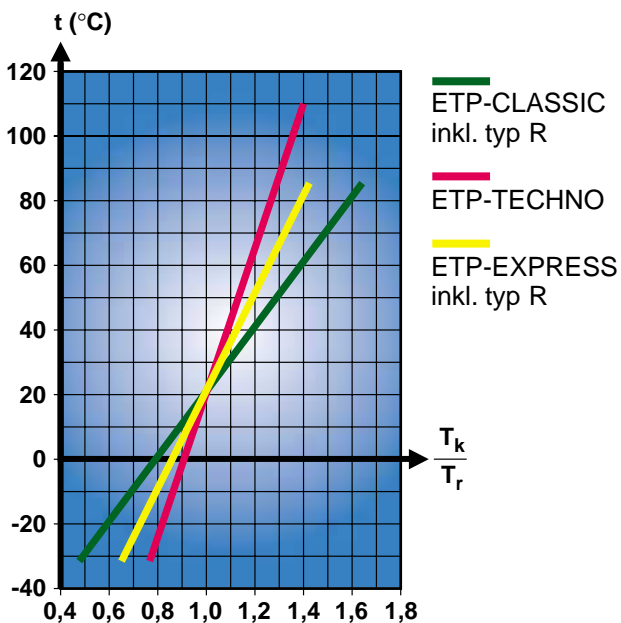

The pressure medium in the hydraulic ETP connections fills the double-walled steel sleeve and is effected by the differing volume expansion coefficient. This means that when the temperature rises, the pressure in the connection increases and a higher torque can be transmitted. The opposite is valid at decreasing temperature.

Also the seals built into the connections decides the upper and lower operating temperature.

The following has to be taken into consideration when the operating temperature differs from the mounting temperature:

- Max. and min. temperature for continuous operation, see table. ETP-MINI and ETP-HYLOC can withstand essentially wider upper and lower limits.
- The decreases in torque due to lower operating temperatures. See diagram. ETP-MINI, ETP-HYLOC and ETP-IMPRESS are not affected.

T_r = transmittable torque acc. to technical data.

T_k = transmittable torque at operating temperature.

ETP connection	Min. temp. °C	Max. temp. °C
ETP-CLASSIC incl. type R	- 30	+ 85
ETP-EXPRESS incl. type R	- 30	+ 85
ETP-TECHNO	- 30	+ 110
ETP-IMPRESS	- 30	+ 85

Keyways

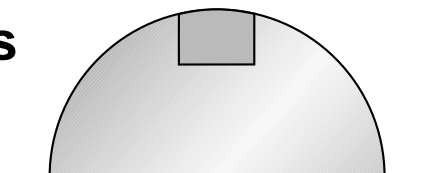

If there is a keyway in the shaft or hub, we recommend it to be filled in with for example some two component hardening medium (not for ETP-MINI or ETP-IMPRESS). The medium is then hand grind to the diameter of the shaft/hub. This prevents deformation and dismantling problems of the double-walled sleeve.

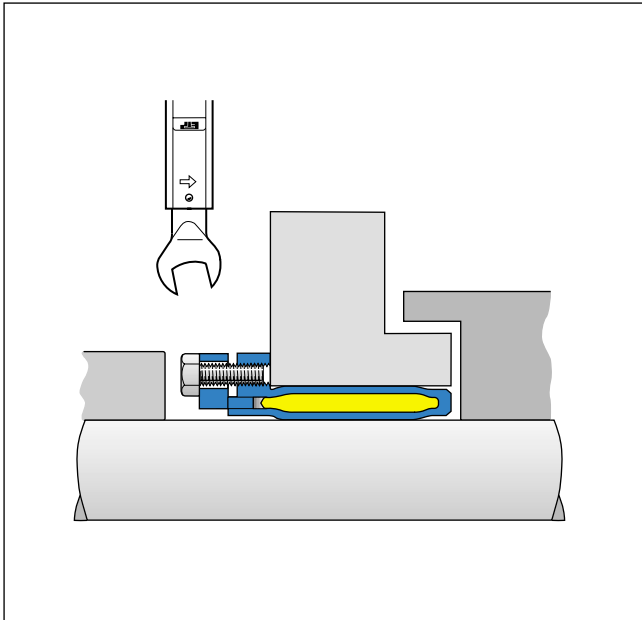

When designing in ETP-CLASSIC and the space is limited in the axial direction, hexhead screws can be used. They are available as accessories in quality 12.9 from us. As no dismantling screws are needed, ETP-CLASSIC can be easily dismantled.

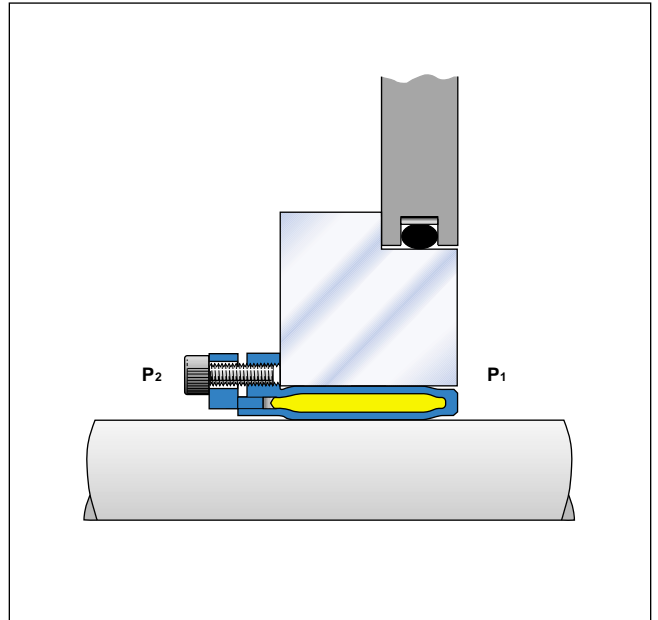

In humid environments, at varying temperature and with a hub made from aluminium ETP-CLASSIC type R can be used. Thanks to the flexibility of ETP-CLASSIC R at varied temperatures, it can be used in hubs of aluminium. Because of the even surface pressure and the lack of slotted sleeves, ETP-CLASSIC R can function as a sealing element up to a pressure difference, $p_1 - p_2$, of 50 bar.

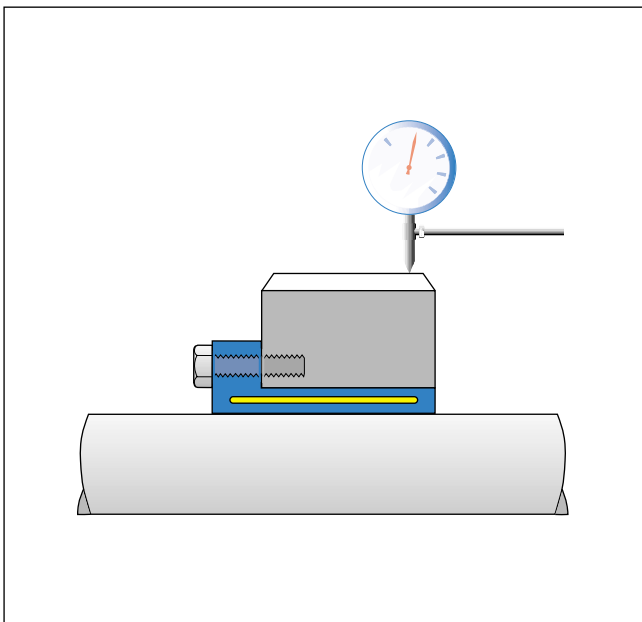

When manufacturing precision gears, they can be fastened with ETP- EXPRESS. If the gear is fixed in its position with an axial screw or pin before the last grinding operation, a repeatability within $2 \mu\text{m}$ will be achieved.

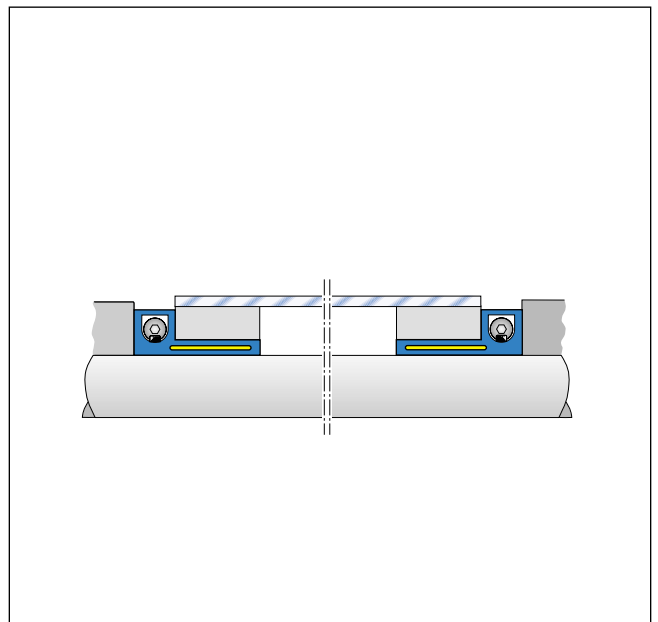

ETP-TECHNO gives advantages when being used to fasten printing cylinders in light materials for example aluminium. The cylinder can be changed 1000's of times, using the same ETP-TECHNO, with maintained good concentricity and repeatability. The radial access to the screw facilitates the handling and saves space.

Technical information Design tips

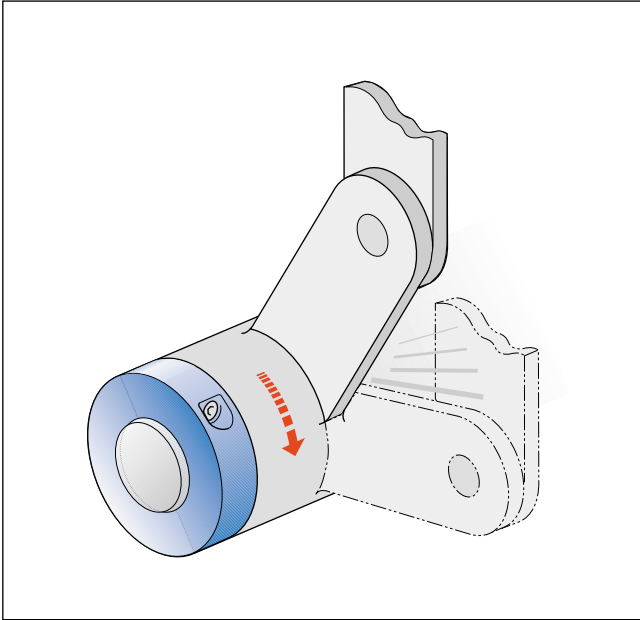

There is a linear ratio between the transmittable torque and the tightening torque for the screw for ETP-EXPRESS and ETP-TECHNO. The torque can be decided for when the connection slips by proper selection of hub/shaft tolerances and tightening torque. The connection can then be used as an overload protection with limited slipping.

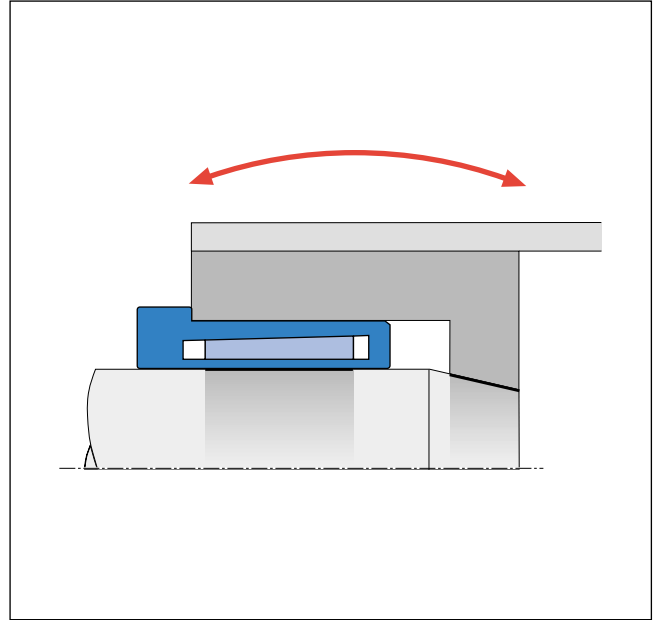

Long thin rollers subjected to high bending torque, can be fastened to stub shafts with ETP-HYLOC. To decrease the elastic deformation of the roller and make it easier to take up the bending torque, the inner part of the hub and the stub shaft can be designed with conical support surfaces. ETP-HYLOC gives good concentricity and fast changes.

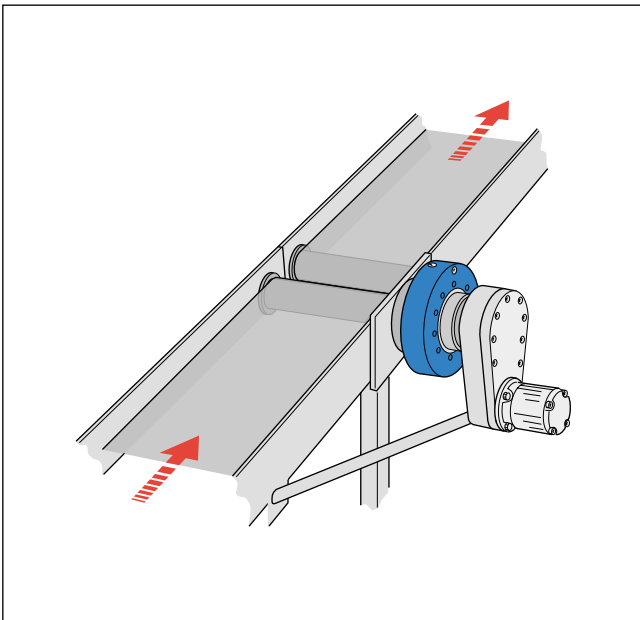

Within the process industry for example papermills, the costs for downtime are high. If one drive unit in a series fails the whole process can stop, the repair and change of faulty items has to be done as quick as possible to save cost. This is easily achieved by using ETP-IMPRESS as a connection between the hollow shaft and shaft thanks to the hydraulic principle.

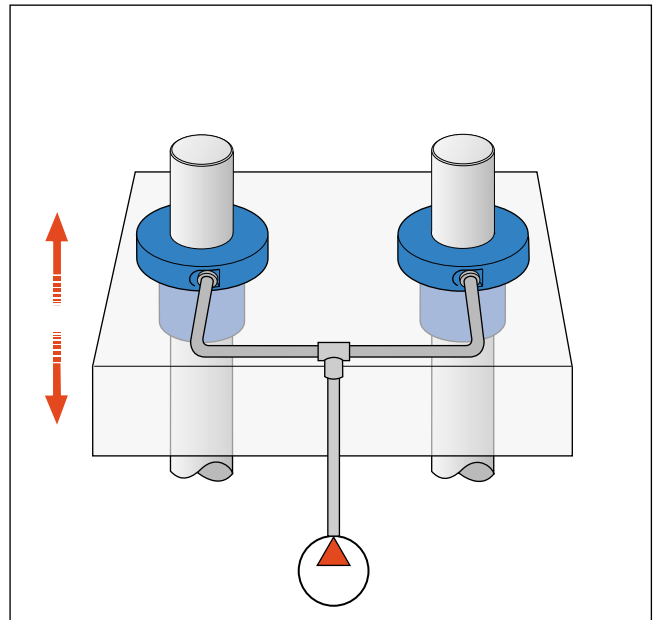

ETP-EXPRESS can be modified to apply a direct hydraulic pressure, with an external hydraulic pump. This can be used for example as a quick locking device for axial positioning.

Tolerances and hydraulic pressure has to be investigated at each individual case. The number of pressure settings has a limit. We assist with the dimensioning and calculations.

ETP-CLASSIC S

Notation ETP-CLASSIC S-XX

ETP-CLASSIC	Dimensions						Transmittable torque or axial force		Screws DIN 912, 12.9			Weight kg
	d mm	D mm	D ₁ mm	L mm	L ₁ mm	L ₂ mm	Tr Nm	Fr kN	No.	Dim.	Tt Nm	
S-19	19	28	45	13	26	31	53	5	3	M5	8	0,15
S-20	20	28	45	15	28	33	75	6	3	M5	8	0,14
S-25	25	34	49	15	29	34	120	10	4	M5	8	0,17
S-30	30	41	57	20	34	39	210	14	4	M5	8	0,24
S-35	35	47	63	22	38	43	330	19	6	M5	8	0,32
S-40	40	53	70	25	42	47	500	26	6	M5	8	0,46
S-45	45	59	77	28	45	51	700	31	6	M6	13	0,57
S-50	50	65	83	26	45	51	1000	40	6	M6	13	0,72

ETP-CLASSIC also has limited availability in a shorter version, type S, which is especially suitable for small hubs. The main dimensions are given in the table, for notations please refer to technical data for ETP-CLASSIC.

TOLERANCES

Shaft: h9 (for size 19: k6 – h8).
Hub: H7.

ETP-CLASSIC in inch

Notation ETP-CLASSIC XXX

ETP-CLASSIC	Dimensions						Transmittable torque or axial force		Screws DIN 912, 12.9		
	d inch	D mm	D ₁ mm	L mm	L ₁ mm	L ₂ mm	Tr Nm	Fr kN	No.	Dim.	Tt Nm
3/4"	3/4"	28	45	21	35	40	88	9,3	3	M5	7
7/8"	7/8"	32	49	22	37	42	135	12,1	4	M5	8
15/16"	15/16"	34	49	25	39	44	175	14,7	4	M5	8
1"	1"	35	51	27	41	46	195	16,2	4	M5	8
1 1/8"	1 1/8"	39	55	29	43	48	280	19,5	4	M5	8
1 3/16"	1 3/16"	41	57	32	47	52	340	22,5	4	M5	8
1 1/4"	1 1/4"	43	60	34	50	55	410	26,1	4	M6	13
1 5/16"	1 5/16"	45	63	35	52	58	475	28,5	4	M6	13
1 3/8"	1 3/8"	47	63	37	53	58	540	31,1	6	M5	8
1 7/16"	1 7/16"	50	65	37	54	59	580	31,8	6	M5	8
1 1/2"	1 1/2"	52	68	41	57	62	700	36,7	6	M5	8
1 5/8"	1 5/8"	55	70	44	63	68	850	41,2	6	M5	8
1 11/16"	1 11/16"	58	77	47	66	72	980	45,7	6	M6	13
1 3/4"	1 3/4"	59	77	49	67	73	1180	53,0	6	M6	13
1 15/16"	1 15/16"	65	83	52	74	80	1450	58,9	6	M6	13
2"	2"	68	88	53	74	80	1620	64,3	6	M6	13
2 3/16"	2 3/16"	74	92	58	83	89	2100	75,6	8	M6	13
2 7/16"	2 7/16"	81	99	60	85	91	2800	90,5	8	M6	13
2 1/2"	2 1/2"	84	107	62	86	94	3100	97,6	6	M8	32
2 15/16"	2 15/16"	95	118	85	108	116	5300	153,0	6	M8	32
3"	3"	98	121	74	101	109	5300	139,1	6	M8	32
3 7/16"	3 7/16"	110	132	90	121	129	7900	181,0	7	M8	32
3 15/16"	3 15/16"	125	148	110	139	147	12500	264,0	8	M8	32
4"	4"	130	155	97	128	136	12500	264,0	8	M8	32

ETP-CLASSIC is also available in a large assortment of inch sizes. The main dimensions are given in the table, for notations please refer to technical data for ETP-CLASSIC.

TOLERANCES

ETP-CLASSIC	Shaft tolerance
3/4"	0 to -0,0015"
7/8" – 1 1/2"	0 to -0,0020"
1 5/8" – 2 15/16"	0 to -0,0030"
3" – 3 7/16"	0 to -0,0040"
3 15/16" – 4"	0 to -0,0030"

ETP-CLASSIC	Hub tolerance
3/4" – 1 15/16"	0 to +0,0010"
2" – 2 7/16"	0 to +0,0012"
2 1/2" – 4"	0 to +0,0014"

ETP-HYLOC >220 mm

ETP-HYLOC	Dimensions					Transmittable torque* M kNm	Min. hub D _H mm	Polar moment of inertia J kgm ²	Weight kg
	d mm	D mm	D ₁ mm	L mm	L ₁ mm				
240	240	325	340	309	334	353	465	2,01	98
260	260	350	365	345	370	473	500	2,96	125
280	280	375	390	361	386	563	536	4,04	148
300	300	400	415	384	409	700	572	5,5	176
320	320	425	440	416	441	897	608	7,5	212
340	340	450	465	440	465	1053	644	9,88	248
360	360	475	490	464	489	1232	680	12,8	289
380	380	495	510	488	513	1461	707	15,5	317
400	400	515	530	511	536	1735	736	18,4	347

ETP-HYLOC is also available for shafts greater than 220 mm. These are manufactured acc. to the customers request. In the table the main dimensions and data are given for shafts up to 400 mm, these can be used as guide lines for the design work. For final dimensioning please contact us.

* With ETP-HFC (High Fiction Coating) treatment of the bore of ETP-HYLOC.

ETP special designs

ETP-UNIGRIP®

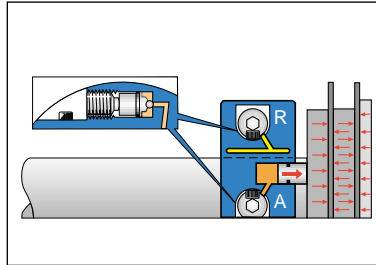

ETP-UNIGRIP has two separate hydraulic functions. When tightening the screw, R, ETP-UNIGRIP grips to the shaft. When tightening screw, A, 3 pistons are pressurized which creates a high axial force against the components which are going to be clamped.

ETP-UNIGRIP is an axial tensioner for clamping for example workpieces and tools against a shoulder on the shaft.

It is available in a limited range of standard sizes for shafts 35 – 65 mm. More information can be sent on request. Special versions also with threaded inner diameter can be offered.

ETP-KN

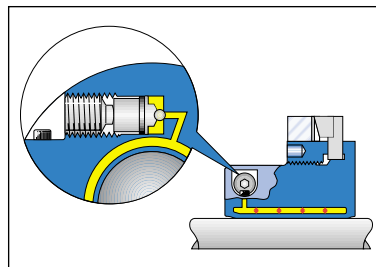

ETP-KN is designed acc. to the same principle as ETP-TECHNO but the expansion is only against the shaft. It is used for example for fastening of circular knives for slitting thin steel-plate when manufacturing beverage and food cans.

The knife is fastened with a nut or with screws onto the flange. ETP-KN gives excellent runout and repeatability as well as fast adjustment. It is only made to customer's specification. Shaft dimensions 50 – 200 mm. Ask for separate information.

Other types

With mainly ETP-TECHNO as a base, new customer specifications are continuously being designed. They solve specific fastening and centering problems. Here are some of the products shown which have been developed through our technician's close co-operation with customers, in order to create the optimal solution.

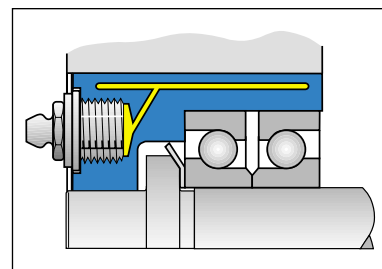
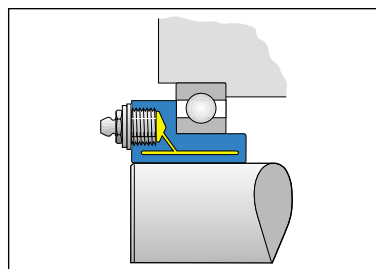

These ETP connections are designed to absorb the very small bearing play in a robot design. With the proper choice of tolerances and pressure in the connection the precision and repeatability of the robot has been improved.

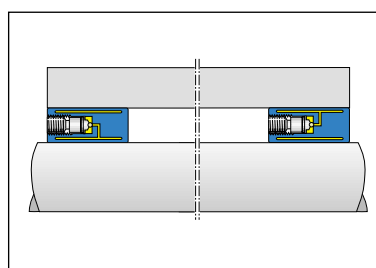

This ETP connection is used for fastening and centering a cylinder in a printing machine for beverage cans of aluminium. It has two separate pressure chambers, one for expansion to the shaft and one to the cylinder. The runout is better and the downtime shorter.

