

ROSTAR[®]

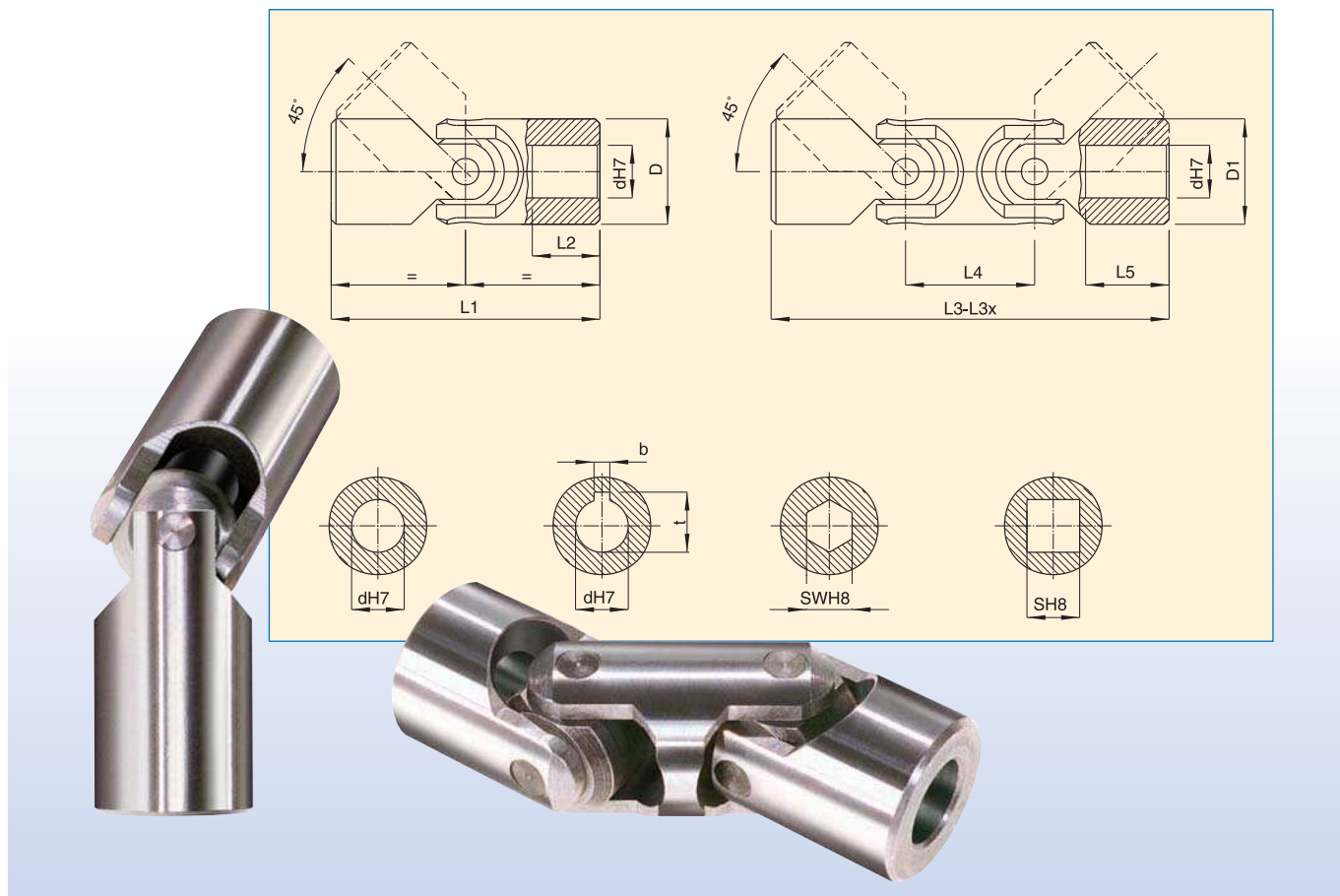

**precision
universal
joints**

Giunti snodati a crociera serie AL Rotar AL series joints



Questo giunto è nato per soddisfare esigenze di economicità unite a una discreta possibilità di trasmettere coppie torsionali.

Il loro impiego è adatto in modo particolare per velocità medio basse con momenti torcenti limitati.

This joint was born to satisfy all the exigences of economy together with a reasonable possibility to transmit torsion couples.

Their employment in mainly fit for medium-low speed and with limited torsion moments.

GIUNTI SEMPLICI SINGLE JOINTS					FORI A RICHIESTA BORES ON REQUEST						GIUNTI DOPPI DOUBLE JOINTS						FORI A RICHIESTA BORES ON REQUEST						
TYPE	dh7	D	L1	L2	dh7	D	L1	L2	L1X	L2X	TYPE	dh7	D1	L3	L3x	L4	L5	dh7	b	t	SH8	SWH8	
100	5	10	40	13	-	-	-	-	-	-	-	-	-	-	-	-	-	-	-	-	-	-	5
101AL	6	13	40	13	-	-	-	-	-	-	101ADL	6	13	63	-	23	13	-	-	-	6	-	
102AL	8	16	40	10	-	-	-	-	-	-	102ADL	8	16	67	-	27	10	-	2	9	8	8	
103AL	10	20	45	10	12	22	50	12	48	62	103ADL	10	20	74	-	29	10	12	3	11,4	10	10	
104AL	12	25	50	11	14	25	56	14	56	74	104ADL	12	22	74	86	29	11	16	4	13,8	12	12	
105AL	14	29	56	13	16	29	65	17	60	74	105ADL	14	25	85	95	33	13	-	5	16,3	14	14	
106AL	16	32	65	15	18	32	72	18	68	86	106ADL	16	29	100	104	35	19	20	5	18,3	16	16	
107AL	18	37	72	17	20	37	82	22	74	-	107ADL	18	32	112	114	39	20	-	6	20,8	18	18	
108AL	20	40	82	19	22	40	95	25	108	-	108ADL	20	40	128	127	46	19	25	6	22,8	20	20	
109AL	22	47	95	22	25	45	108	28	-	-	109ADL	22	40	145	-	46	25	-	6	24,8	22	22	
110AL	25	50	108	27	30	50	122	34	105	132	110ADL	25	50	163	-	59	24	-	8	28,3	25	25	
111AL	30	58	122	30	35	58	140	39	166	-	111ADL	30	58	182	-	66	30	-	8	33,3	30	30	

L1X, L2X, L3X, a richiesta (on request)

Giunti snodati a crociera serie AL con attacco rapido *AL series joints with quick release*

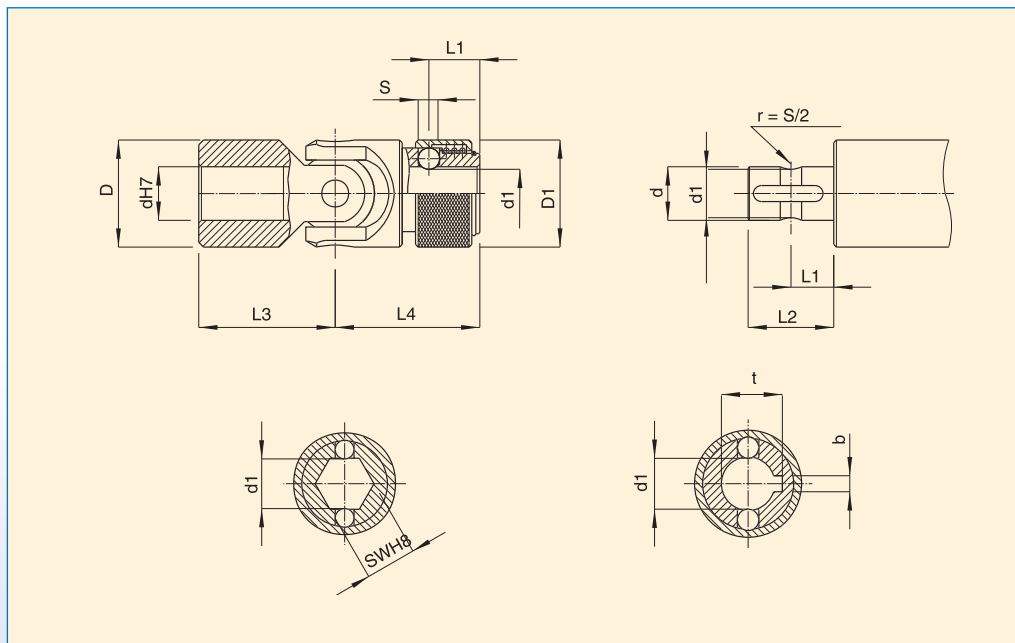

TIPO - TYPE	d	D1	l1	l2	l3	l4	S	SW	d1	bxt
103ALR	10	20	11,5	17	22,5	31	4	10	8,7	3x11,2
104ALR	12	25	13,5	21	25	37	4	12	11	4x13,3
105ALR	14	29	13,5	21	28	37	4	14	13	5x15,3
106ALR	16	32	14	25	32,5	43	6,3	16	14,8	5x17,3
107ALR	18	37	19	33	36	50	8	18	16	6x19,8
108ALR	20	40	19	33	41	54	8	20	18	6x21,8
109ALR	22	47	20,5	38	47,5	60	10	22	20	6x23,8
110ALR	25	50	20,5	38	54	66	10	25	23	8x26,8
111ALR	30	58	25	50	61	83	10	30	28	8x32,2

Giunti cardanici a crociera in acciaio inossidabile *High precision cardan joints in stainless steel*

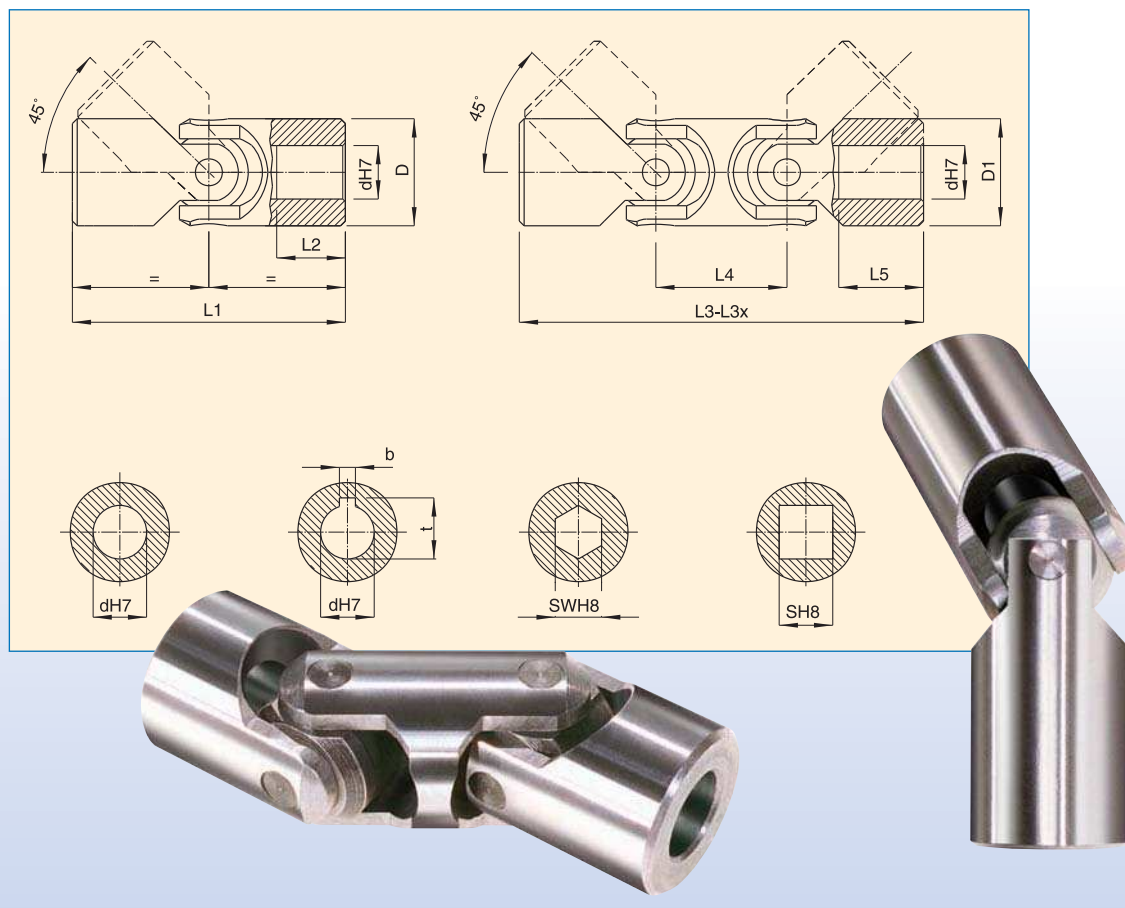

I giunti rappresentati ampliano la gamma della produzione ROTAR.

Sono costruiti in ACCIAIO INOSSIDABILE X5CrNi1810 e vengono impiegati in particolare nelle industrie ALIMENTARI E FARMACEUTICHE.

The joints shown increase the range of ROTAR products.

They are built in STAINLESS STEEL X5CrNi1810 and they are normally used for FOOD AND PHARMACEUTICAL INDUSTRIES.

GIUNTI SEMPLICI SINGLE JOINTS					GIUNTI DOPPI DOUBLE JOINTS						FORI A RICHIESTA BORES ON REQUEST		
TYPE	dh7	D	L1	L2	TYPE	dh7	D1	L3	L4	L5	S	SWH8	bxt
100X	5	10	44	15	-	-	-	-	-	-	-	5	-
101X	6	13	50	18	-	-	-	-	-	-	6	-	-
102X	8	16	58	19	-	-	-	-	-	-	8	8	2x9
103X	10	22	76	25	-	-	-	-	-	-	10	10	3x11,4
104X	12	25	86	29	104DX	12	22	105	29	25	12	12	4x13,8
105X	14	29	90	30	105DX	14	25	119	33	29	14	14	5x16,3
106X	16	32	95	30	106DX	16	29	125	35	30	16	16	5x18,3
107X	18	37	108	35	107DX	18	32	134	39	30	18	18	6x20,8
108X	20	40	108	32	108DX	20	40	154	46	32	20	20	6x22,8
109X	22	47	127	38	109DX	22	40	173	46	38	22	22	6x24,8
110X	25	50	140	44	110DX	25	50	199	59	44	25	25	8x28,3
111X	30	58	178	58	111DX	30	58	244	66	58	30	30	8x33,3

Giunti di alta precisione a forcella Din 808-7551

High precision cardan joints with hardened bushes

Semplici max. α 45° - Doppi max. α 90° / Singles max. α 45° - Doubles max. α 90°

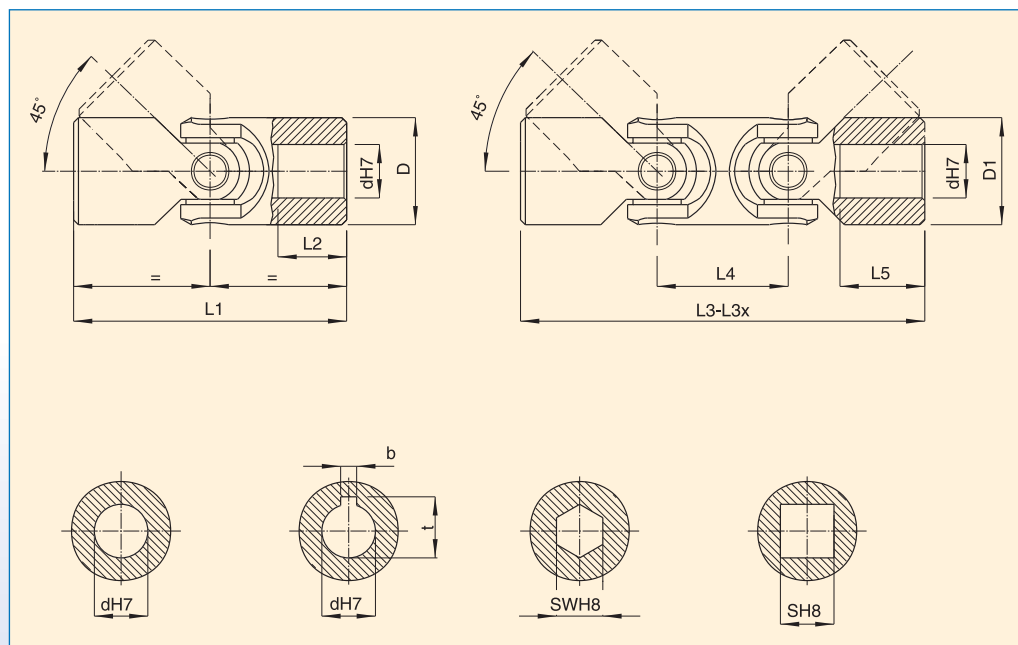

GIUNTI SEMPLICI SINGLE JOINTS							GIUNTI DOPPI DOUBLE JOINTS							FORI A RICHIESTA BORES ON REQUEST					
TYPE	dh7	D	I1	L2	L1 on request		TYPE	dh7	D1	L3	L5	L3X	L4	dh7	b	t	Sh8	SWh8	
101A	6	16	34	9	-	-	101AD	6	16	61	-	-	27	-	-	-	-	-	
102A	8	16	40	11	58	-	102AD	8	16	67	-	-	27	10	2	9	-	-	
103A	10	22	45	10	48	62	76	103AD	10	20	75	-	-	30	12	3	11,4	10	10
103/1A	10	20	45	10	48	62	-	-	-	-	-	-	-	12	3	11,4	10	10	
104A	12	25	50	11	56	86	74	104AD	12	22	74	11	86	29	16	4	13,8	12	12
105A	14	29	56	13	60	74	90	105AD	14	25	85	13	95	33	-	5	16,3	14	14
106A	16	32	65	15	68	86	95	106AD	16	29	100	19	104	35	20	5	18,3	16	16
107A	18	37	72	17	74	108	-	107AD	18	32	112	20	114	39	-	6	20,8	18	18
108A	20	40	82	19	108	127	-	108AD	20	40	128	19	-	46	25	6	22,8	20	20
109A	22	47	95	22	127	-	-	109AD	22	40	145	25	-	48	-	6	24,8	22	22
110A	25	50	108	26	105	132	140	110AD	25	50	163	24	-	59	32	8	28,3	25	25
111A	30	58	122	30	166	178	-	111AD	30	58	182	28	-	66	-	8	33,3	30	30
111/1A	32	63	130	30	-	-	-	111/1AD	32	63	198	30	-	84	-	10	35,3	30	35
112A	35	70	140	35	-	-	-	112AD	35	70	212	32	-	78	-	10	38,3	-	35
113A	40	80	160	42	-	-	-	113AD	40	80	245	38	-	95	-	12	43,3	-	35
114A	50	95	190	54	-	-	-	114AD	50	95	290	50	-	120	-	14	53,8	-	35



Questi giunti cardanci a forcella sono ottenuti grazie ad una accurata costruzione, con tolleranze ristrette; offrono grandi prestazioni. Una particolare tecnica di rettifica rende possibile un preciso parallelismo degli assi e delle singole parti di un giunto. Viene così garantita una lunga durata. Tutte le parti a contatto sono temperate, rettificata e lappate.

These joints are the result of a careful construction, with restricted tolerances; so they can offer great performances. A particular grinding technic realizes a perfect parallelism of the axes and the single parts of the joint. All the parts in touch are hardened, grounded and lapped.

Trasmissione con giunti di precisione serie a forcetta

Slip shafts with high precision cardan joints

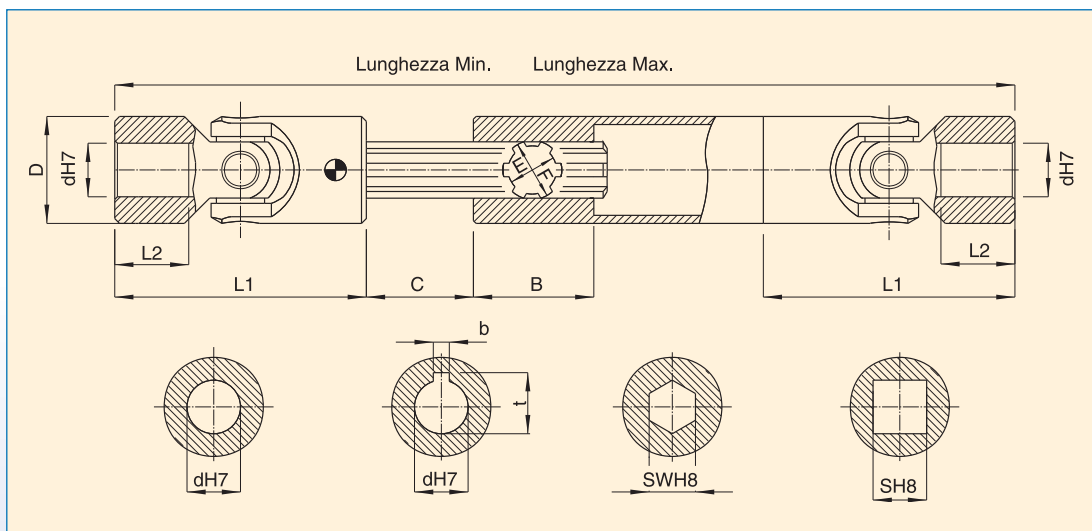

Esempio di ordinazione: 125A1301502BT: Trasmissione tipo 125A L. min. 130 - L. max. 150 con 2 cave
Order example: 125A1301502BT: Slip shaft type 125A L. min. 130 - L. max. 150 with 2 keyways

MISURE PRONTE - STOCK MEASURE												
TIPO TYPE	L. min/max	Cave keyways										
			dh7	D	L1	L2	B	bxt	c=corsa	E	F	
125A	130/150	2BT	10	22	45	10	40	3 X 11,4	20	11	14	
125A	140/170	2BT	10	22	45	10	40	3 X 11,4	30	11	14	
125A	160/200	2BT	10	22	45	10	40	3 X 11,4	40	11	14	
125A	170/230	2BT	10	22	45	10	40	3 X 11,4	60	11	14	
125A	180/240	2BT	10	22	45	10	40	3 X 11,4	60	11	14	
125A	230/330	2BT	10	22	45	10	40	3 X 11,4	100	11	14	
126A	140/170	2BT	12	25	50	11	45	4 X 13,8	30	13	16	
126A	160/200	2BT	12	25	50	11	45	4 X 13,8	40	13	16	
126A	180/225	2BT	12	25	50	11	45	4 X 13,8	45	13	16	
126A	200/270	2BT	12	25	50	11	45	4 X 13,8	70	13	16	
126A	220/300	2BT	12	25	50	11	45	4 X 13,8	80	13	16	
126A	250/355	2BT	12	25	50	11	45	4 X 13,8	105	13	16	
126A	280/420	2BT	12	25	50	11	45	4 X 13,8	140	13	16	
126A	300/450	2BT	12	25	50	11	45	4 X 13,8	150	13	16	

MISURE PRONTE - STOCK MEASURE											
TIPO	L.	Cave									
TYPE	min/max	keyways	dh7	D	L1	L2	B	bxt	c=corsa	E	F
127A	160/190	2BT	14	29	56	13	45	5 X 16,3	30	13	16
127A	170/200	2BT	14	29	56	13	45	5 X 16,3	30	13	16
127A	180/220	2BT	14	29	56	13	45	5 X 16,3	40	13	16
127A	200/260	2BT	14	29	56	13	45	5 X 16,3	60	13	16
127A	210/280	2BT	14	29	56	13	45	5 X 16,3	70	13	16
127A	220/300	2BT	14	29	56	13	45	5 X 16,3	80	13	16
127A	250/350	2BT	14	29	56	13	45	5 X 16,3	100	13	16
127A	280/420	2BT	14	29	56	13	45	5 X 16,3	140	13	16
127A	300/450	2BT	14	29	56	13	45	5 X 16,3	150	13	16
127A	350/550	2BT	14	29	56	13	45	5 X 16,3	200	13	16
127A	400/650	2BT	14	29	56	13	45	5 X 16,3	250	13	16
128A	180/210	2BT	16	32	65	15	45	5 x 18,3	30	16	20
128A	190/220	2BT	16	32	65	15	45	5 x 18,3	30	16	20
128A	210/250	2BT	16	32	65	15	45	5 x 18,3	40	16	20
128A	240/320	2BT	16	32	65	15	45	5 x 18,3	80	16	20
128A	250/350	2BT	16	32	65	15	45	5 x 18,3	100	16	20
128A	275/390	2BT	16	32	65	15	45	5 x 18,3	115	16	20
128A	300/430	2BT	16	32	65	15	45	5 x 18,3	130	16	20
128A	380/590	2BT	16	32	65	15	45	5 x 18,3	210	16	20
128A	400/630	2BT	16	32	65	15	45	5 x 18,3	230	16	20
129A	195/225	2BT	18	37	72	17	45	6 x 20,8	30	16	20
129A	230/280	2BT	18	37	72	17	45	6 x 20,8	50	16	20
129A	250/320	2BT	18	37	72	17	45	6 x 20,8	70	16	20
129A	270/370	2BT	18	37	72	17	45	6 x 20,8	100	16	20
129A	290/400	2BT	18	37	72	17	45	6 x 20,8	110	16	20
129A	300/415	2BT	18	37	72	17	45	6 x 20,8	115	16	20
129A	400/620	2BT	18	37	72	17	45	6 x 20,8	220	16	20
129A	500/820	2BT	18	37	72	17	45	6 x 20,8	320	16	20
130A	220/250	2BT	20	40	82	19	45	6 x 22,8	30	18	22
130A	250/300	2BT	20	40	82	19	45	6 x 22,8	50	18	22
130A	270/340	2BT	20	40	82	19	45	6 x 22,8	70	18	22
130A	290/380	2BT	20	40	82	19	45	6 x 22,8	90	18	22
130A	320/440	2BT	20	40	82	19	45	6 x 22,8	120	18	22
130A	380/560	2BT	20	40	82	19	45	6 x 22,8	180	18	22
130A	420/640	2BT	20	40	82	19	45	6 x 22,8	220	18	22
130A	500/800	2BT	20	40	82	19	45	6 x 22,8	300	18	22
131A	250/280	2BT	22	47	95	22	48	6 x 24,8	30	21	25
131A	270/320	2BT	22	47	95	22	48	6 x 24,8	50	21	25
131A	290/350	2BT	22	47	95	22	48	6 x 24,8	60	21	25
131A	330/430	2BT	22	47	95	22	48	6 x 24,8	100	21	25
131A	350/470	2BT	22	47	95	22	48	6 x 24,8	120	21	25
131A	470/710	2BT	22	47	95	22	48	6 x 24,8	240	21	25
132A	270/320	2BT	25	50	108	26	48	8 x 28,3	50	23	28
132A	295/350	2BT	25	50	108	26	48	8 x 28,3	55	23	28
132A	310/375	2BT	25	50	108	26	48	8 x 28,3	65	23	28
132A	350/450	2BT	25	50	108	26	48	8 x 28,3	100	23	28
132A	380/500	2BT	25	50	108	26	48	8 x 28,3	120	23	28
132A	420/590	2BT	25	50	108	26	48	8 x 28,3	170	23	28
132A	460/660	2BT	25	50	108	26	48	8 x 28,3	200	23	28
132A	500/745	2BT	25	50	108	26	48	8 x 28,3	245	23	28
133A	320/390	2BT	30	58	122	30	50	8 x 33,3	70	26	32
133A	350/420	2BT	30	58	122	30	50	8 x 33,3	70	26	32
133A	370/455	2BT	30	58	122	30	50	8 x 33,3	85	26	32
133A	400/510	2BT	30	58	122	30	50	8 x 33,3	110	26	32
133A	450/620	2BT	30	58	122	30	50	8 x 33,3	170	26	32
133A	500/720	2BT	30	58	122	30	50	8 x 33,3	220	26	32
133A	540/795	2BT	30	58	122	30	50	8 x 33,3	255	26	32
134A			35	70	140	35	50			A RICHIESTA	
135A			40	80	160	42	50			A RICHIESTA	
136A			50	95	190	54	50			A RICHIESTA	

Manicotti in gomma per la protezione dei giunti cardanici
Rubber boots for the protection of the cardan joints

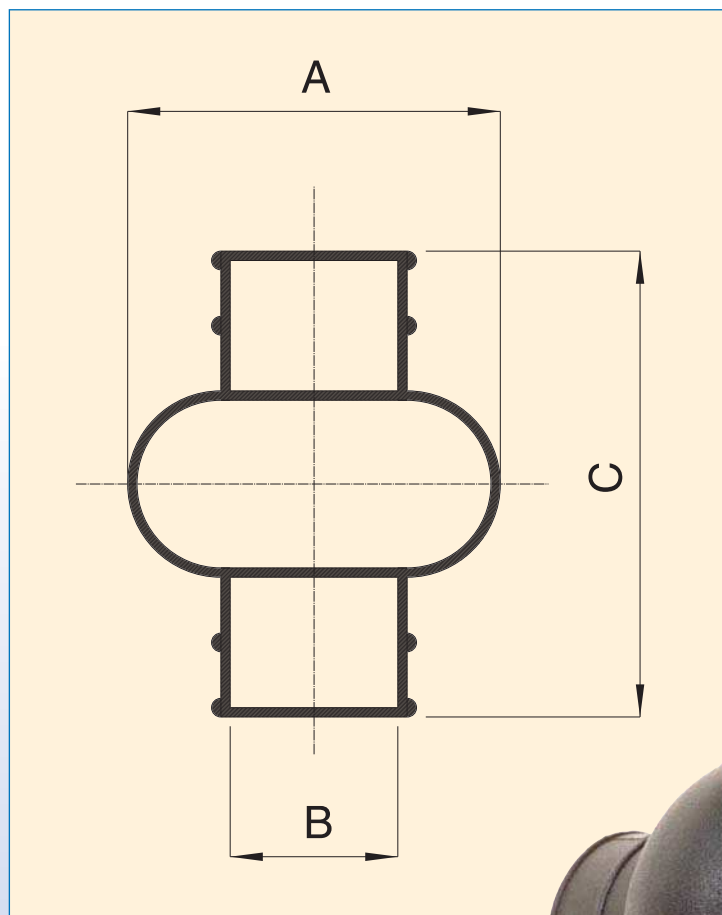

TIPO	FORO GIUNTO	MISURE MANICOTTO - RUBBER MEASURES		
TYPE	JOINT BORE	A	B	C
103G	10	39	20,5	47
104G	12	47	24,5	52
105G	14	51	27,5	58
106G	16	56	30,5	67
107G	18	66	35,5	74
108G	20	75	40	84
109G	22	83	45	97
110G	25	93	50	110
111G	30	105	56	124

Giunti snodati di alta precisione con cuscinetti ad aghi High precision cardan joints with needle bearings

Semplici max. α 45° - Doppi max. α 90° / Singles max. α 45° - Doubles max. α 90°

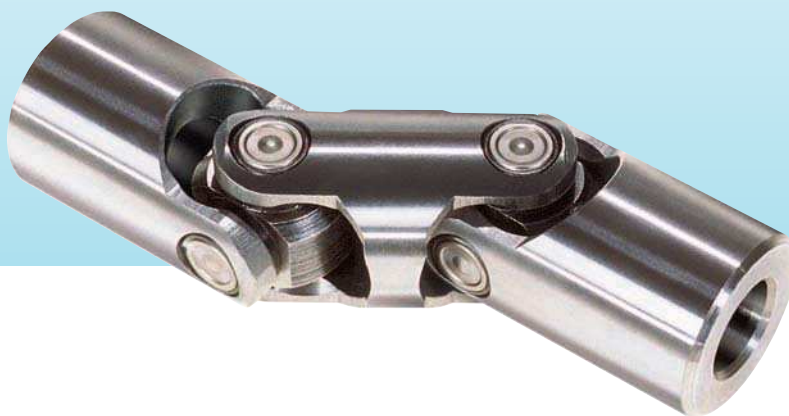
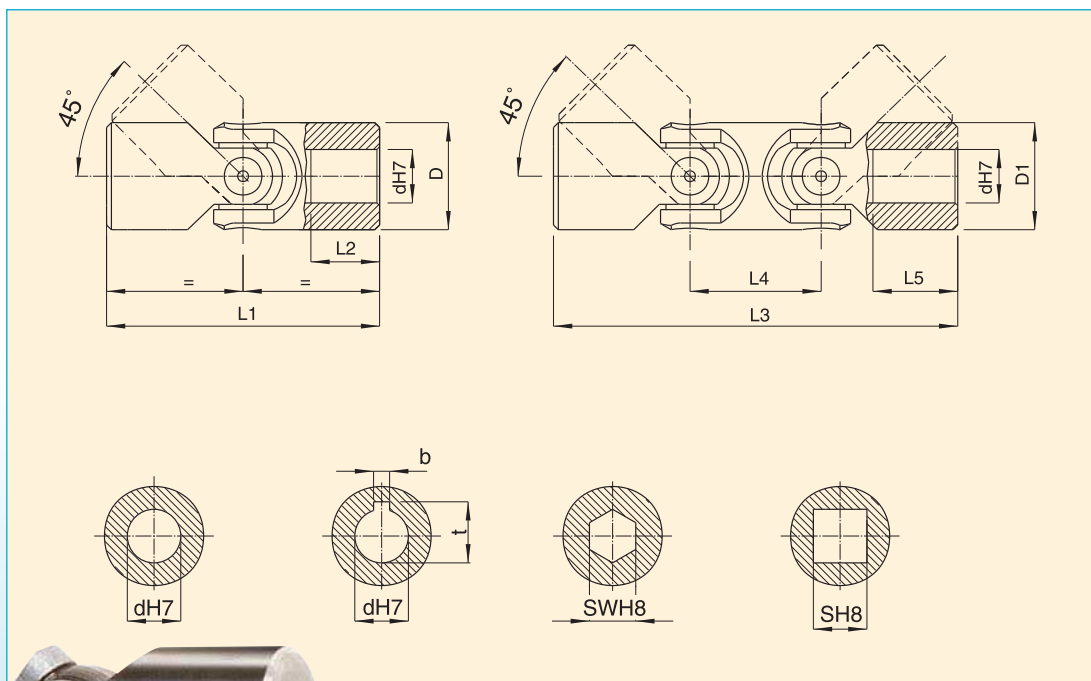

GIUNTI SEMPLICI SINGLE JOINTS					GIUNTI DOPPI DOUBLE JOINTS						FORI A RICHIESTA BORES ON REQUEST		
TYPE	dh7	D	L1	L2	TYPE	dh7	D1	L3	L4	L5	S	SWH8	bxt
102V	8	16	52	15	-	-	-	-	-	-	-	-	2x9
103V	10	20	62	18	103DV	10	20	88	26	18	10	10	3x11,4
105V	14	25	74	20	105DV	14	25	104	33	19	14	14	5x16,3
106V	16	32	86	24	106DV	16	32	125	39	24	16	16	5x18,3
107V	18	37	72	17	-	-	-	-	-	-	18	18	6x20,8
108V	20	40	108	30	108DV	20	40	156	48	30	20	20	6x22,8
109V	22	47	95	22	-	-	-	-	-	-	22	22	6x24,8
110V	25	50	132	38	110DV	25	50	188	59	37	25	25	8x28,3
111V	30	63	166	45	111DV	30	63	238	80	41	30	30	8x33,3
111/1V	32	63	166	45	111/1DV	32	63	238	80	41	-	-	8x35,3
112V	35	70	140	35	112DV	35	70	212	78	30	-	35	10x38,3
113V	40	80	180	50	113DV	40	80	290	120	48	-	35	12x43,3
114V	50	95	190	54	114DV	50	95	290	120	50	-	35	14x53,8

Giunti snodati di alta precisione con crociere cardaniche High precision cardan joints with cross

Semplici max. α 45° - Doppi max. α 90° / Singles max. α 45° - Doubles max. α 90°

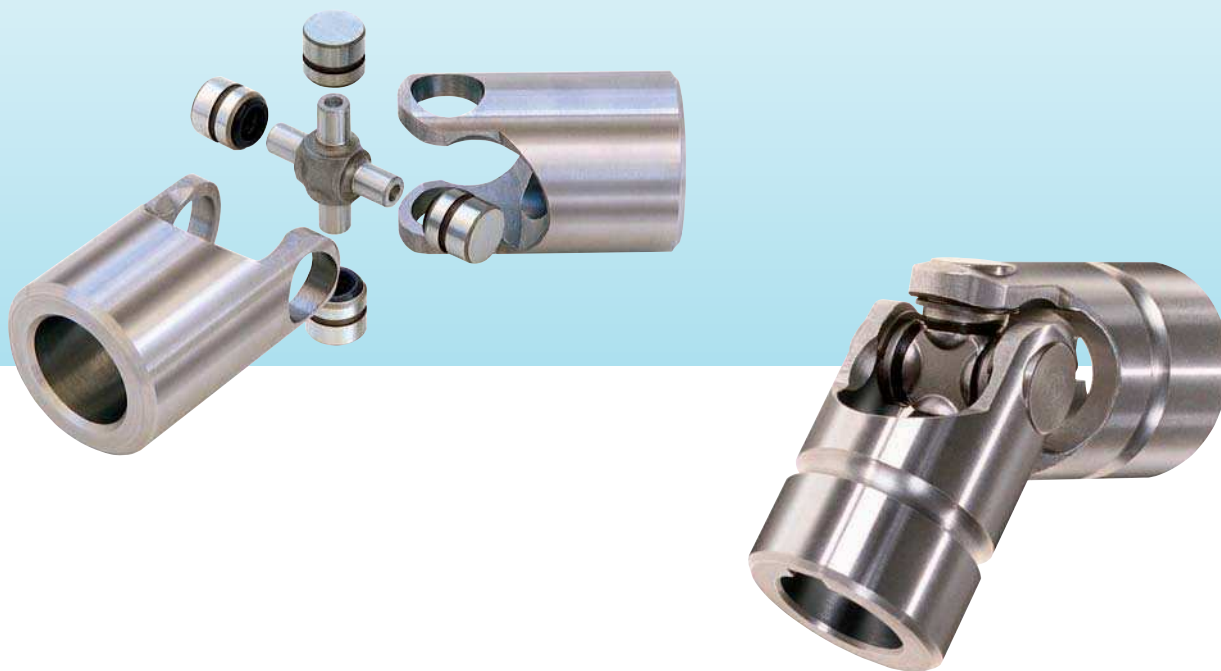
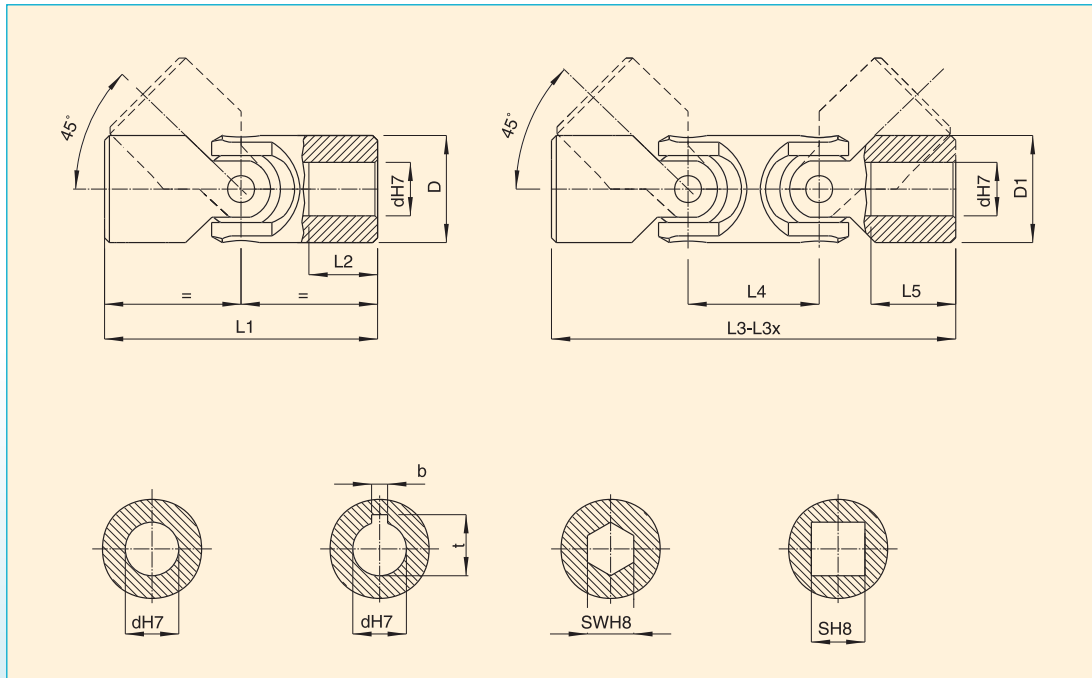

GIUNTI SEMPLICI SINGLE JOINTS					GIUNTI DOPPI DOUBLE JOINTS						FORI A RICHIESTA BORES ON REQUEST		
TYPE	dh7	D	L1	L2	TYPE	dh7	D1	L3	L4	L5	S	SWH8	bxt
106VC	16	32	86	24	106DVC	16	32	125	39	24	16	16	5x18,3
108VC	20	40	108	30	108DVC	20	40	156	48	30	20	20	6x22,8
110VC	25	50	132	38	110DVC	25	50	188	59	37	25	25	8x28,3
111VC	30	63	166	45	111DVC	30	63	238	80	41	30	30	8x33,3

Trasmissione con giunti di precisione con cuscinetti ad aghi *Slip shafts with needle bearings joints*

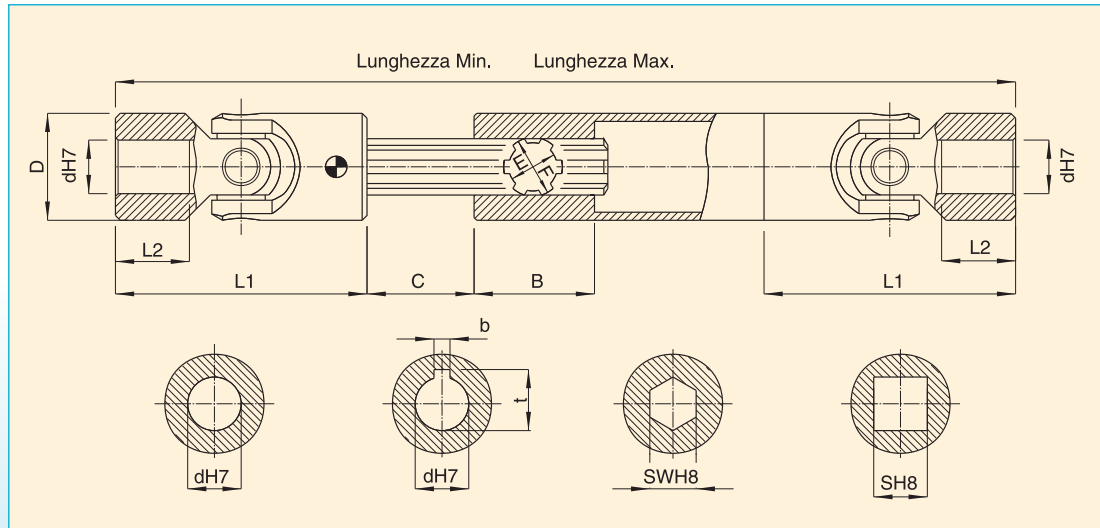

Lunghezza "L" a richiesta

$$L \text{ min} = (2 \times L1) + B + C$$

$$L \text{ max} = (2 \times L1) + B + (2 \times C)$$

$$C = L \text{ max} - L \text{ min}$$

Esecuzione normale con foro tondo

cave - quadri - esagoni - a richiesta

l'albero scanalato in esecuzione normale è trafilato

Possiamo fornire fresati - temperati - rettificati

"L" lenght on request

$$\text{min } L = (2 \times L1) + B + C$$

$$\text{max } L = (2 \times L1) + B + (2 \times C)$$

$$C = \text{max } L - \text{min } L$$

Normal execution is with circular bore

Keyways - square - hexagon - on request

The splined shaft is normally supplied drawn

We can supply the splined
milled - hardened - grounded.

TIPO - TYPE	dh7	D	I1	I2	B	bxt	SH8	SWH8	E	F
125V	10	20	62	18	40	3x11,4	10	10	11	14
127V	14	25	74	20	45	5x16,3	14	14	13	16
128V - 128VC	16	32	86	24	45	5x18,3	16	16	16	20
129V	18	37	72	17	45	6x20,8	18	18	16	20
130V - 130VC	20	40	108	30	45	6x22,8	20	20	18	22
131V	22	47	95	22	48	6x24,8	22	22	21	25
132V - 132VC	25	50	132	38	48	8x28,3	25	25	23	28
133V - 133VC	30	63	166	45	50	8x33,8	30	30	32	38
134V	35	70	140	35	70	10x38,3	-	35	32	38
135V	40	80	180	50	70	12x43,3	-	35	42	48
136V	50	95	190	54	70	14x53,8	-	35	42	48

Criteri di scelta dei giunti *Criteria for selection of joints*

Le tabelle riportate danno le massime coppie consentite (esprese in Kgm) sono state rilevate dopo funzionamento prolungato con angolo di inclinazione di 10°.

Se l'angolo di inclinazione supera i 10° i valori riportati vengono ridotti secondo i fattori di coppia sotto riportati.

The tables give the maximum allowable torque (expressed in Kgm) calculated on the basis with an angle of inclination of 10° and continuous use.

If the inclination angle is over 10° the values shown will be reduced in accordance with the torque factors shown below.

ANGOLO α ANGLE UP TO	ANGOLO F FACTOR F
5°	1,25
10°	1
20°	0,75
30°	0,45
40°	0,30
45°	0,25

Esempio: criteri di scelta del giunto adatto, secondo la potenza da trasmettere, la velocità e l'angolo di inclinazione.

Siano:

la potenza N 3 CV

la velocità n 2000 giri/min.

angolo α 20°

Il momento torcente corrispondente é uguale:

$$Mt = \frac{716,2 \times N}{n} = \frac{716,2 \times 3}{2000} = 1,074 \text{ Kgm}$$

La coppia da trasmettere é di 1,074 Kgm ma essendo l'angolo di 20° si dovrà scegliere un giunto di dimensioni maggiori con una coppia di trasmissione più elevata.

Essendo il fattore di coppia per 20° di 0,75 (come indicato dalla tabella) si divide il Mt per F.

$$\frac{MT}{F} = \frac{1,074}{0,75} \quad MT \ 1,432 \text{ Kgm}$$

Il giunto appropriato dovrà avere la coppia di trasmissione di 1,432 Kgm che secondo la tabella dei giunti con cuscinetti é il tipo 105V.

Si tenga presente che 1 Kgm = 9,80665 Nm

Example: criteria for selection of joint after taking into account the power to be transmitted, the speed and the angle of inclination:

Example:

power N3 CV

speed n 2000 revs per minute

angle α 20°

The corresponding torque moment is:

The torque to be transmitted is 1074 Kgm but since the joint angle is 20° one must select a joint of larger dimension and torque carrying capacity to compensate.

Since the torque factor for 20° is 0,75 (as indicated on the table) one divides the Mt by F.

The appropriate joint should have a torque capability of 1432 Kgm or greater which is selected from the table of joint with needle bearings is type 105V.

Pay attention that 1 Kgm = 9,80665 Nm

Momenti torcenti Torsion moments

In Nm



Giunti serie AL AL series joints

		VELOCITA' min. 1' - SPEED min. 1'						
TIPO - TYPE		100	200	300	400	500	700	800
-	100	5,5	5	4,2	3,8	3,5	-	-
-	100AL	6,6	6,6	5,3	4,8	4,4	-	-
-	102AL	13	9	8	7	6	5,2	4,7
125AL	103AL	25	17	15	12	11	10	7
126AL	104AL	45	25	21	16	14	11	9
127AL	105AL	70	45	40	33	30	26	22
128AL	106AL	88	85	72	55	50	43	34
129AL	107AL	160	120	100	68	58	54	-
130AL	108AL	240	170	120	90	80	72	-
131AL	109AL	300	200	150	110	93	-	-
132AL	110AL	390	250	180	140	115	-	-
133AL	111AL	430	330	200	150	128	-	-

PER I GIUNTI DOPPI UTILIZZARE IL VALORE PARI AL 90% DEI MOMENTI TORCENTI CITATI
FOR DOUBLE JOINTS USE THE VALUE EQUIVALENT TO 90% OF THE MENTIONED TORSION MOMENTS

Giunti in acciaio inossidabile Joints in stainless steel

		VELOCITA' min. 1' - SPEED min. 1'						
TIPO - TYPE		100	200	300	400	500	700	800
100X		3,6	3,3	2,8	2,5	2,3	-	-
101X		4,4	4,4	3,5	3,2	2,9	-	-
102X		8,6	6	5,3	4,6	4	3,4	3,1
103X		12,3	8,3	7	6,4	5,8	5,2	3,5
104X		21	12,6	10	8	7,3	6,3	5,8
105X		33	21,3	19,3	17,6	16,3	13,3	12,6
106X		45	42	35,3	28	25,3	20	17,3
107X		76	60	46,6	35,3	29,3	23,3	-
108X		117	84	58,6	46,6	41,3	29,3	-
109X		146	96	70	58,6	46,6	35,3	-
110X		192	120	84	72	60	48	-
111X		216	132	96	78	66	-	-

PER I GIUNTI DOPPI UTILIZZARE IL VALORE PARI AL 90% DEI MOMENTI TORCENTI CITATI
FOR DOUBLE JOINTS USE THE VALUE EQUIVALENT TO 90% OF THE MENTIONED TORSION MOMENTS



Giunti di precisione a forcella *joints with hardened bushes*

TIPO - TYPE	VELOCITA' min. 1' - SPEED min. 1'						
	100	200	300	400	500	700	800
103A - 104AD - 125A	25	17	14,5	13	12	11	7,5
104A - 105AD - 126A	43	25	20,5	17	15,5	13	12
105A - 106AD - 127A	68,5	43	39,5	36	33,5	28,5	26,5
106A - 107AD - 128A	86,5	84	72	57,5	51,5	41	36
107A - 129A	156	120	96	72	60	48	-
108A - 108AD - 109AD - 130A	240	168	120	96	84	60	-
109A - 131A	300	192	144	120	96	72	-
110A - 110AD - 132A	384	240	168	144	120	96	-
111A - 111AD - 111/1A - 133A	432	264	192	156	132	-	-
112A - 112AD - 134A	456	300	228	174	144	-	-
113A - 113AD - 135A	504	336	264	216	-	-	-
114A - 114AD - 136A	720	480	336	264	-	-	-

PER I GIUNTI DOPPI UTILIZZARE IL VALORE PARI AL 90% DEI MOMENTI TORCENTI CITATI
FOR DOUBLE JOINTS USE THE VALUE EQUIVALENT TO 90% OF THE MENTIONED TORSION MOMENTS

Giunti con cuscinetti *Needle bearings joints*

TIPO - TYPE	VELOCITA' min. 1' - SPEED min. 1'					
	250	500	1000	2000	3000	4000
102V	-	-	-	5,8	-	-
103V - 103DV - 125V	22	17	14	11	10	9
105V - 105DV - 127V	34	29	24	22	20	18
106V - 106DV - 106VC - 128V	65	55	45	40	37	32
107V - 129V	75	61	50	45	40	36
108V - 108DV - 108VC - 130V	140	120	100	80	70	65
109V - 131V	162	132	108	88	77	71
110V - 110DV - 110VC - 132V	200	170	130	110	90	85
111V - 111DV - 111VC - 133V	300	270	230	190	160	140
112V - 112DV - 134V	326	277	237	198	168	-
113V - 113DV - 135V	365	303	255	205	186	-
114V - 114DV - 136V	402	335	275	225	198	-

PER I GIUNTI DOPPI UTILIZZARE IL VALORE PARI AL 90% DEI MOMENTI TORCENTI CITATI
FOR DOUBLE JOINTS USE THE VALUE EQUIVALENT TO 90% OF THE MENTIONED TORSION MOMENTS